

# SOLVA

Intelligent • Integrated • In Control

Technical Brochure

freedom  
WON



# The SOLVA Range

## 261kWh

### SOLVA AC261

#### Integrated PCS Architecture

- AC Bus parallel capability
- Simplified deployment
- Optional STS



### SOLVA DC261

#### Flexible DC-Coupled Architecture

- External inverter compatibility
- Scale with inverter AC parallel
- DC parallel up to 12



### SOLVA RT261

#### Dual Conversion Architecture

- Independent grid-based charging
- Isolated load Bus
- Protects against poor grid quality



## 418kWh

### SOLVA AC418

#### Integrated 690VAC PCS Architecture

- AC bus parallel capability
- Larger scale cabinet deployment
- Use with MV step-up transformer



### SOLVA Naming Convention:

All SOLVA models follow the pattern: [Category] + [Capacity] = Model

AC = Alternating Current  
DC = Direct Current  
RT = Rectifier

Category

+

261 = 261kWh  
418 = 418kWh

Capacity

=

AC261 / AC418  
DC261  
RT261

Model

## Advanced Thermal Management

All **SOLVA** models incorporate active liquid thermal management to maintain stable battery operating temperatures across varying environmental and load conditions.

### Thermal Management Features:

- Integrated liquid **cooling** system
- Integrated liquid **heating** system
- Intelligent temperature regulation of battery and PCS

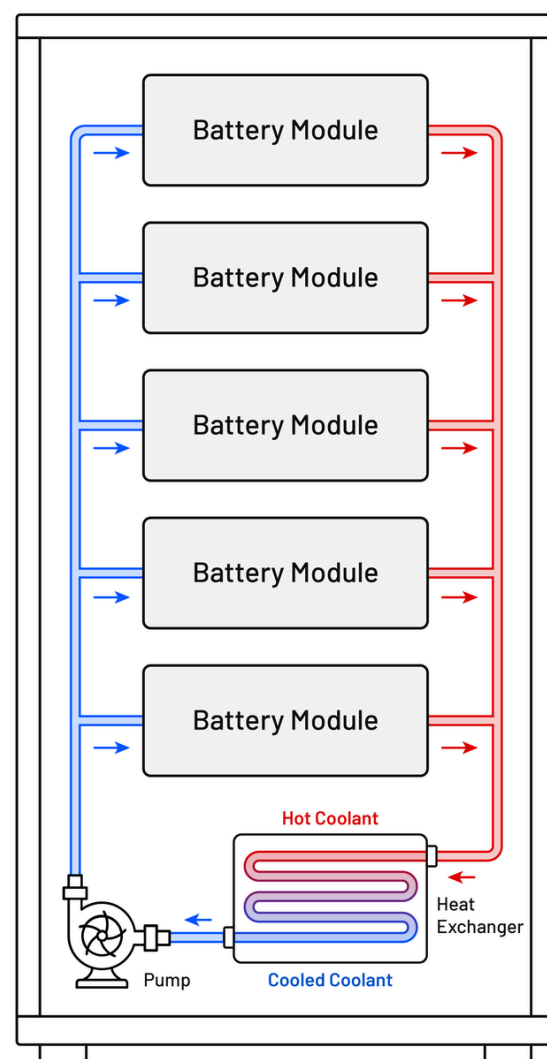

Feature	System Benefit
Stable operating temperatures	Improved reliability
Reduced thermal stress	Increased battery lifespan
Consistent temperature distribution	Enhanced performance stability
High-load thermal handling	Improved operational efficiency
Built-in heating and cooling	Enables outdoor use in a wider range of conditions

## Safety & Environmental Protection

**SOLVA** is designed to support demanding operational environments through intelligent thermal management, integrated safety systems and durable enclosure protection.

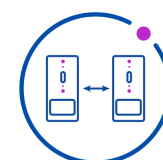

**Risk Mitigation** - Separate cabinets mitigates the risk of incidents propagating through the system



**Cabinet Management System (CMS)** - Monitoring system level safety within the cabinet



**Aerosol Fire Suppression** - Integrated cabinet-level suppression

**IP55 Protection Rating** - Suitable for:



Outdoor installations



Industrial environments



Harsh weather environments



Dust-resistant

**C5 Corrosion Protection** - Designed for:



Coastal environments



High-humidity conditions

# Intelligent Monitoring & System Control

Integrated monitoring systems provide real-time operational visibility and coordinated system management.

## Cabinet Monitoring System (CMS)

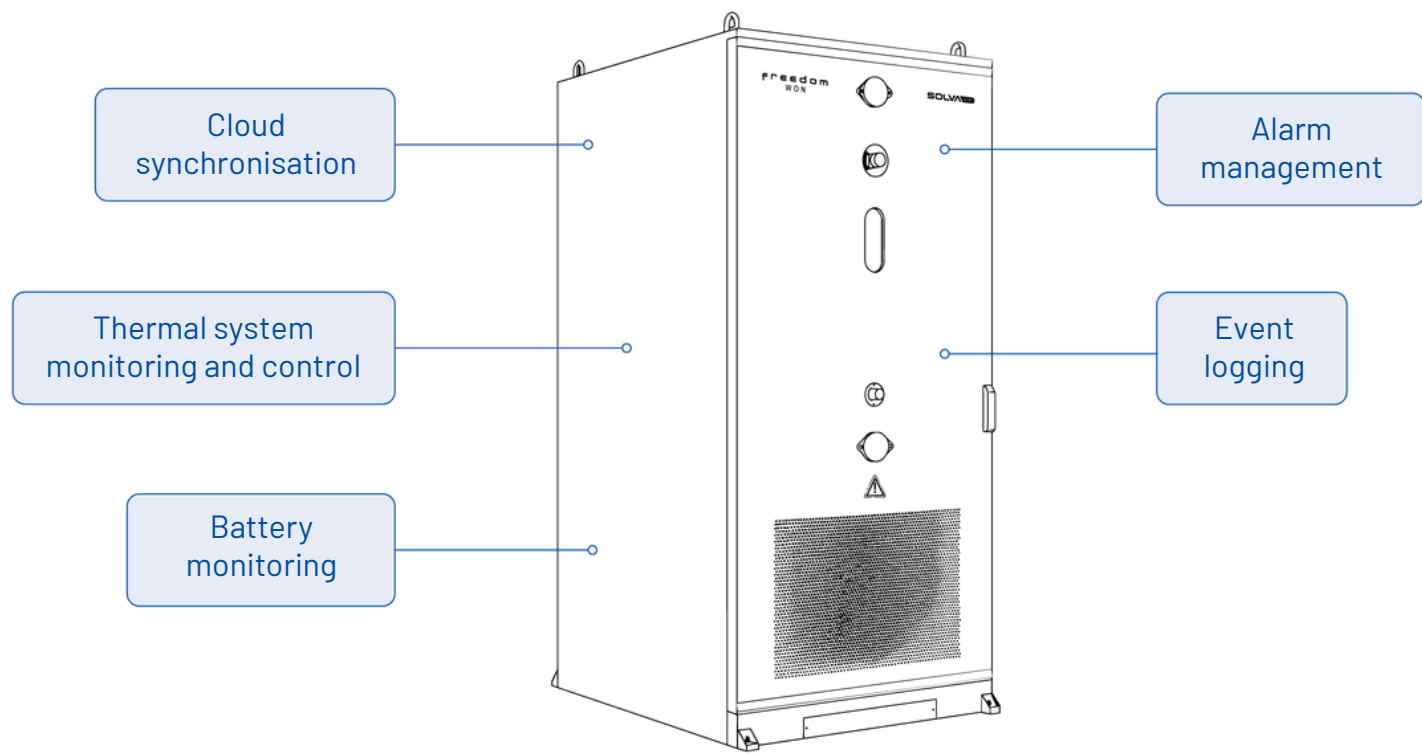

### Operational Advantages:

- Remote system visibility
- Simplified diagnostics
- Improved maintenance planning
- Enhanced operational control
- EMS integration capability

Interface	Function
RS485	EMS communication
CAN	BMS communication
LAN	Network integration

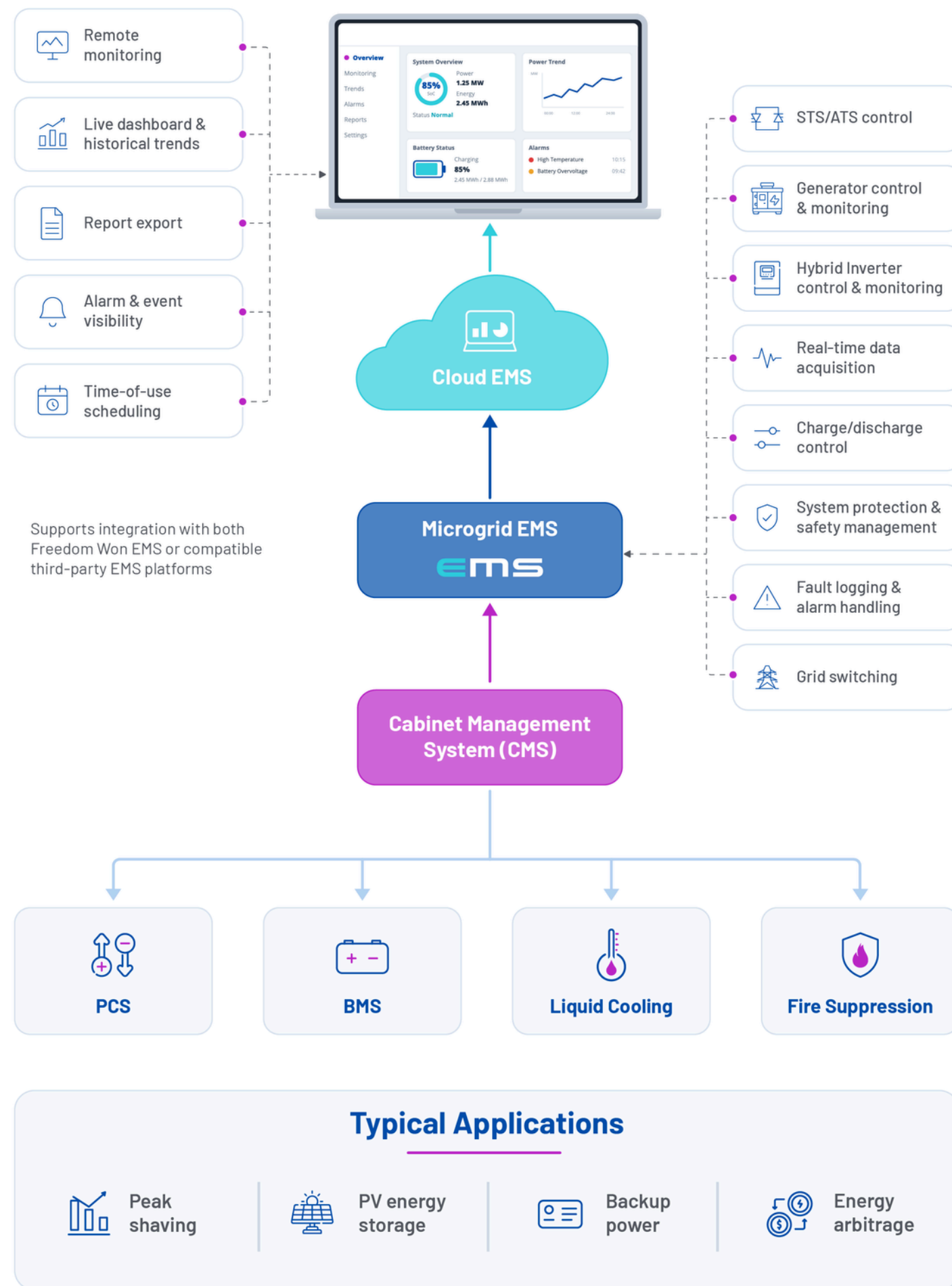

SOLVA AC261

The SOLVA AC261 combines 261kWh LiFePO<sub>4</sub> battery storage, integrated 125kW PCS and intelligent system control, combined into a unified AC-coupled energy storage platform.

Key Features

- Integrated AC-coupled energy storage for rapid commercial deployment
- NRS 097-2-1, AS/NZS 4777.2:2020 certified
- Optional STS for sub 20ms switching



Feature	Advantage
Integrated 125kW PCS	Reduced external integration requirements
Transformerless topology	Lower balance of system cost
Power factor control	Full active and reactive power capability
Parallel scalability	<b>On-Grid Expansion:</b> 20 cabinets in parallel; <b>Off-Grid Expansion:</b> 8 cabinets in parallel
Robust PCS	Black start capability, built-in VSG, 50% inductive loads

Standards & Certifications:

UN38.3, IEC 62619, IEC62477, IEC60730, IEC61000, IEC60529, NRS 097-2-1, AS/NZS 4777.2:2020

Standard Warranty:

5 years (Warranty extension available)

Specifications

DC-SIDE PARAMETERS	
Cell Capacity [Ah]	314
Battery Chemistry	Lithium Iron Phosphate (LiFePO <sub>4</sub> )
Total Energy Capacity [kWh]	261
System Depth of Discharge [%]	90
Nominal Voltage [V]	832
Max/Min. Operating Voltage [V]	936/728
Cell Configuration	1P52S per module, 5 modules per pack
Battery Pack Thermal Management System	Liquid Heating and Cooling
AC CONNECTION PARAMETERS	
Integrated PCS rated power [kW]	125
System Output AC Voltage [V]	400
Rated Frequency [Hz]	50/60
AC Connection Method	(3P+N+PE) Three-Phase, Four-Wire System
Power Factor Range	Adjustable from 1.0 leading to 1.0 lagging, with full active or reactive power capability
Total Current Harmonic Distortion (THD-I) [%]	<2 (at Rated Power)
Isolation Type	Transformerless
AC Cable Entry	Bottom Entry
LIQUID THERMAL MANAGEMENT	
Max. Auxiliary Power [kW]/Current [A]	2.8/13.4
Cooling Capacity [kW]	5
Heating Capacity [kW]	2
SYSTEM PARAMETERS	
System Total Efficiency [%]	≥88
Dimensions (H×W×D) ±5 [mm]	2346x1050x1376
Weight [Tons]	2.7
Ingress Protection	IP55
Corrosion Protection Class	C5
Inverter Thermal Management System	Intelligent Air Cooling
Monitoring and Control	Built-in Cabinet Monitoring System (CMS) interfaces with site EMS for coordinated control, monitoring, and logging of BMS, PCS, and thermal systems. Includes local data storage and cloud synchronisation for remote access.
Communication Interface	RS485 (EMS), CAN (BMS), PARA (STS), LAN (Network)
Parallel Configuration	On-Grid mode supports up to 20 cabinets in parallel. Off-Grid mode supports up to 8 cabinets in parallel.
Protection	AC overcurrent protection, AC overvoltage protection, AC short-circuit protection, anti-islanding protection, reverse polarity protection (DC side)
Fire Suppression System	Aerosol
ENVIRONMENTAL PARAMETERS	
Operating Temperature [°C]	-20 to 55
Operating humidity [%]	≤95
Max. Operating Altitude [m]	Full load up to 2000m; above that, derate 10% per 1000m up to 4000m

# System Architecture Diagram

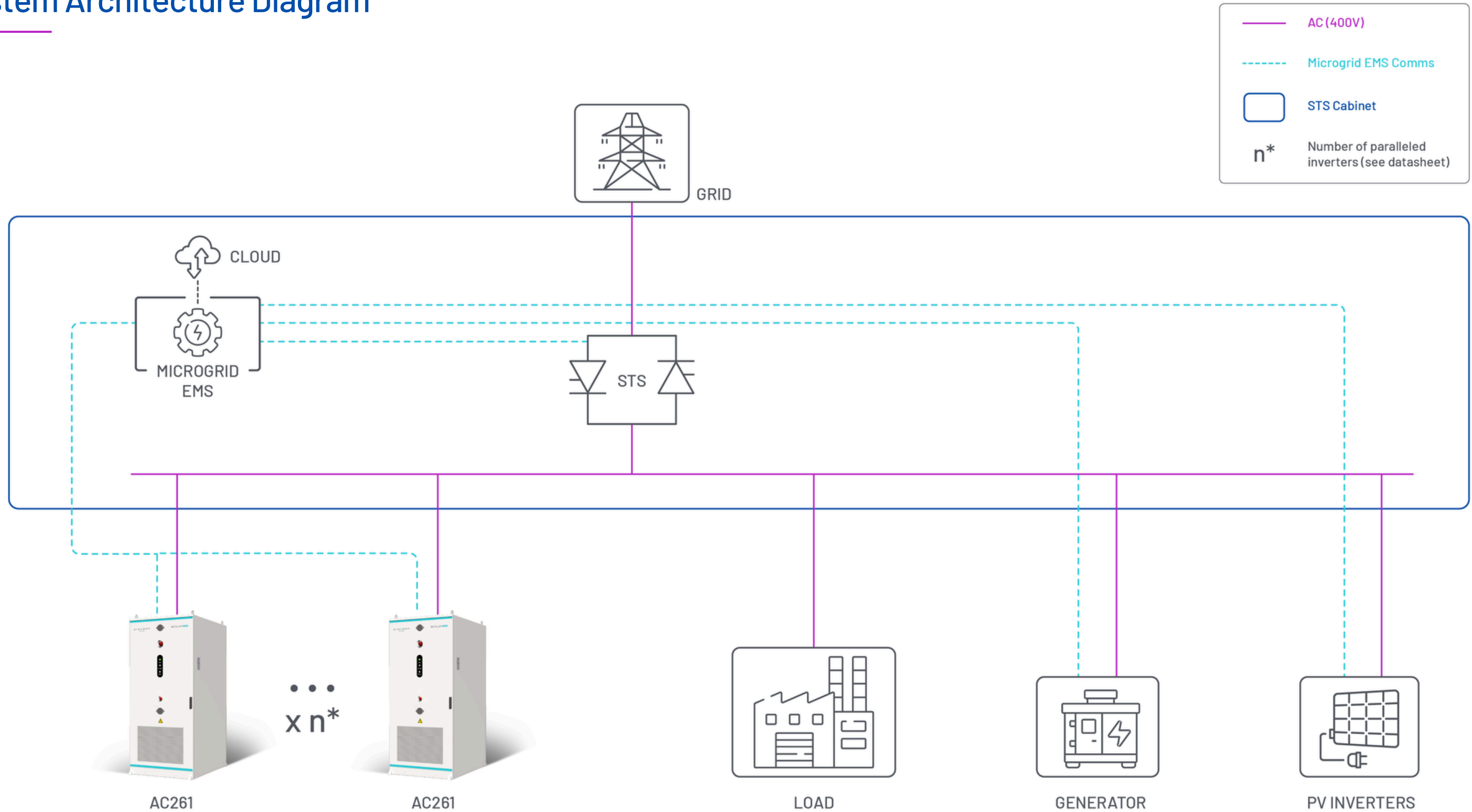

# SOLVA DC261

The SOLVA DC261 is a high-voltage DC-coupled energy storage cabinet designed for integration with external hybrid and central inverter systems.

Its integrated DC busbar configuration supports scalable system expansion, flexible inverter selection and simplified DC-side integration.

## Key Features

- For projects requiring external inverter integration
- External hybrid inverter can be mounted to the side of the cabinet



Hybrid inverter not included. For illustrative purposes only.

Feature	Advantage
Integrated DC busbars	Simplified DC integration
832V nominal voltage	Suits popular hybrid inverters, e.g. Solis
665.6V/209kWh configuration available	For alternative inverter compatibility options
DC parallel scalability	Flexible system expansion of up to 12 units

## Versatile Energy Storage Solutions

### Hybrid Systems

The SOLVA DC261 integrates with popular hybrid inverter brands, supporting cost-effective deployment of medium-sized commercial projects.

### Central Inverter Systems

Compatible with central inverter configurations, the SOLVA DC261 enables scalable energy deployment with optimised DC-side integration and efficient system expansion.

## Specifications

PARAMETERS	
Cell Capacity [Ah]	314
Battery Chemistry	Lithium Iron Phosphate (LiFePO4)
Total Energy Capacity [kWh]	261
System Depth of Discharge [%]	90
Nominal Voltage [V]	832
Max/Min. Operating Voltage [V]	936/728
Cell Configuration	1P52S per module, 5 modules per pack
Battery Pack Thermal Management System	Liquid Heating and Cooling
CONNECTION METHOD	
External Hybrid Inverter Connection	Integrated DC Busbars - rated for 125kW
DC Cabinet Parallel Connection	A maximum of 12 cabinets can be connected in parallel (additional controller required). External inverters connected in AC parallel.
External Inverter Communication Interface	CAN Bus
DC Cable Entry	Bottom Entry
LIQUID THERMAL MANAGEMENT	
Max. Auxiliary Power [kW]/Current [A]	2.8/13.4
Cooling Capacity [kW]	5
Heating Capacity [kW]	2
SYSTEM PARAMETERS	
Dimensions (HxWxD) ±5 [mm]	2346x1050x1376
Weight [Tons]	2.5
Ingress Protection	IP55
Corrosion Protection Class	C5
Monitoring and Control	Built-in Cabinet Monitoring System (CMS) interfaces with site EMS for coordinated control, monitoring, and logging of BMS, and thermal systems. Includes local data storage and cloud synchronisation for remote access.
Communication Interface	RS485 (EMS), CAN (BMS), LAN (Network)
Protection	DC Breaker
Fire Suppression System	Aerosol
ENVIRONMENTAL PARAMETERS	
Operating Temperature [°C]	-20 to 55
Operating humidity [%]	≤95
Max. Operating Altitude [m]	Full load up to 2000m; above that, derate 10% per 1000m up to 4000m

### Standards & Certifications:

UN38.3, IEC 62619, IEC62477, IEC60730, IEC61000, IEC60529

### Standard Warranty:

5 years (Warranty extension available)

# System Architecture Diagram

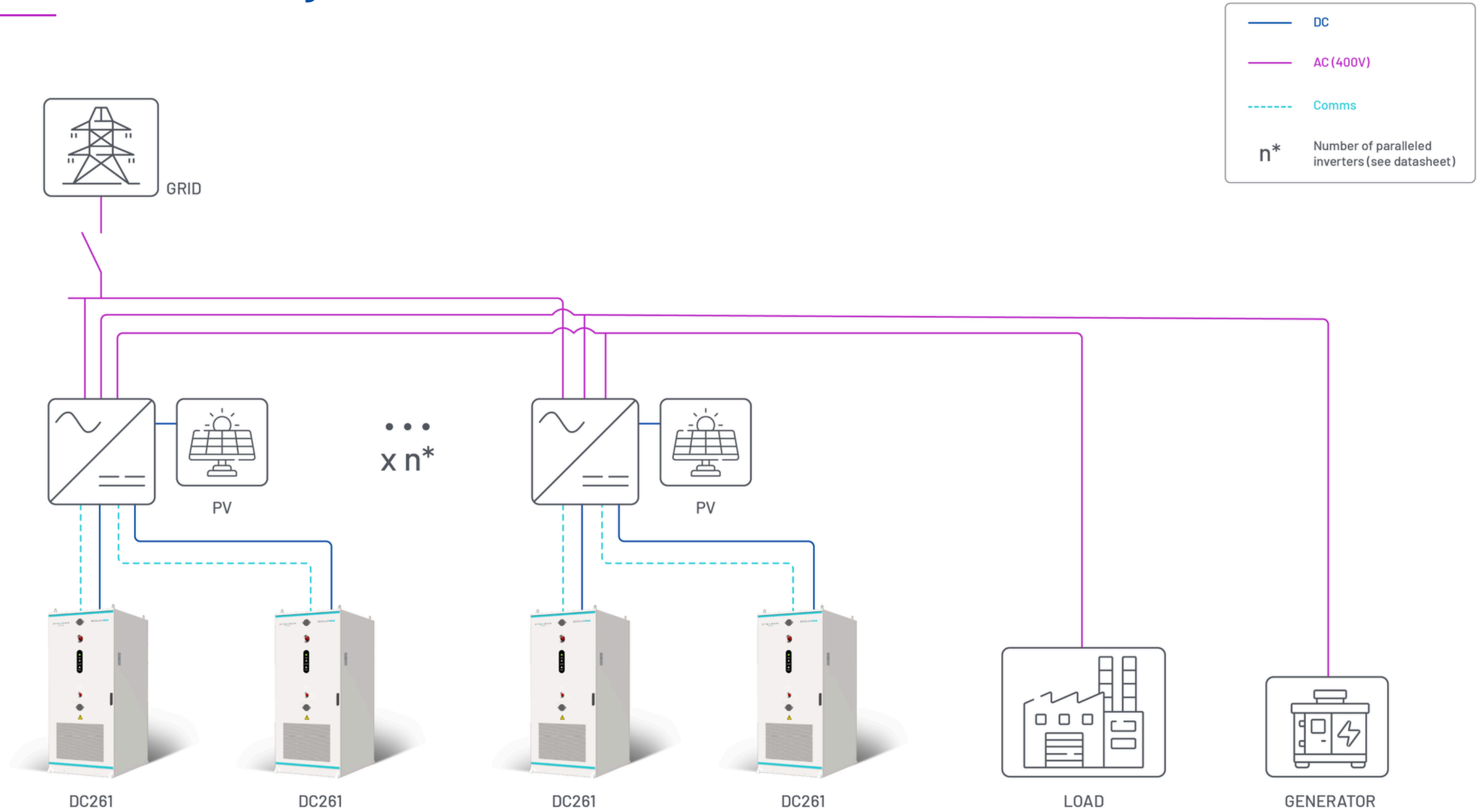

# SOLVA RT261

The SOLVA RT261 integrates 261kWh high-voltage LiFePO<sub>4</sub> storage with a 125kW rectifier system for direct DC bus charging and central or hybrid inverter integration.

Its transformerless rectifier topology supports efficient power conversion, low harmonic distortion and scalable DC-coupled system deployment.

## Key Features

- Dual conversion for poor grid quality, and no voltage dip while transitioning to off-grid.
- NRS 097-2-1, AS/NZS 4777.2:2020 certified.

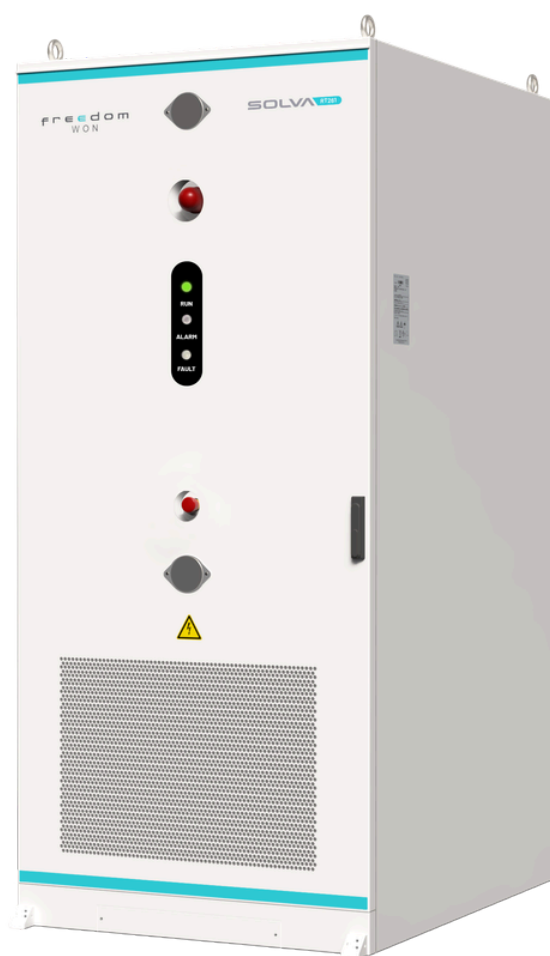

Feature	Advantage
Integrated 125kW rectifier	Reduced external integration requirements
832V nominal DC voltage	Suits popular hybrid inverters, e.g. Solis
665.6V/209kWh configuration available	For alternative inverter compatibility options
Transformerless topology	Lower balance of system cost
DC parallel scalability up to 12 cabinets	Scalable expansion for central inverter systems

### Standards & Certifications:

UN38.3, IEC 62619, IEC62477, IEC60730, IEC61000, IEC60529, NRS 097-2-1, AS/NZS 4777.2:2020

### Standard Warranty:

5 years (Warranty extension available)

## Specifications

PARAMETERS	
Cell Capacity [Ah]	314
Battery Chemistry	Lithium Iron Phosphate (LiFePO <sub>4</sub> )
Total Energy Capacity [kWh]	261
System Depth of Discharge [%]	90
Nominal Voltage [V]	832
Max/Min. Operating Voltage [V]	936/728
Cell Configuration	1P52S per module, 5 modules per pack
Battery Pack Thermal Management System	Liquid Heating and Cooling
DC CONNECTION METHOD	
External Hybrid Inverter Connection	Integrated DC Busbars - rated for 125kW
DC Cabinet Parallel Connection	A maximum of 12 cabinets in DC parallel (additional controller required). External inverters connected in AC parallel.
External Inverter Communication Interface	CAN Bus
DC Cable Entry	Bottom Entry
AC CONNECTION METHOD	
Integrated Rectifier rated power [kW]	125
System Input AC Voltage [V]	400
Rated Frequency [Hz]	50/60
AC Connection Method	(3P+N+PE) Three-Phase, Four-Wire System
Total Current Harmonic Distortion (THD-I) [%]	<2 (at Rated Power)
Isolation Type	Transformerless
AC Cable Entry	Bottom Entry
LIQUID THERMAL MANAGEMENT	
Max. Auxiliary Power [kW]/Current [A]	2.8/13.4
Cooling Capacity [kW]	5
Heating Capacity [kW]	2
SYSTEM PARAMETERS	
System Total Efficiency [%]	≥88
Dimensions (H×W×D) ±5 [mm]	2346x1050x1376
Weight [Tons]	2.5
Ingress Protection	IP55
Corrosion Protection Class	C5
Monitoring and Control	Built-in Cabinet Monitoring System (CMS) interfaces with site EMS for coordinated control, monitoring, and logging of BMS, and thermal systems. Includes local data storage and cloud synchronisation for remote access.
Communication Interface	RS485 (EMS), CAN (BMS), LAN (Network)
Protection	AC overcurrent protection, AC overvoltage protection, AC short-circuit protection, anti-islanding protection, reverse polarity protection (DC side)
Fire Suppression System	Aerosol
ENVIRONMENTAL PARAMETERS	
Operating Temperature [°C]	-20 to 55
Operating humidity [%]	≤95
Max. Operating Altitude [m]	Full load up to 2000m; above that, derate 10% per 1000m up to 4000m

# System Architecture Diagram

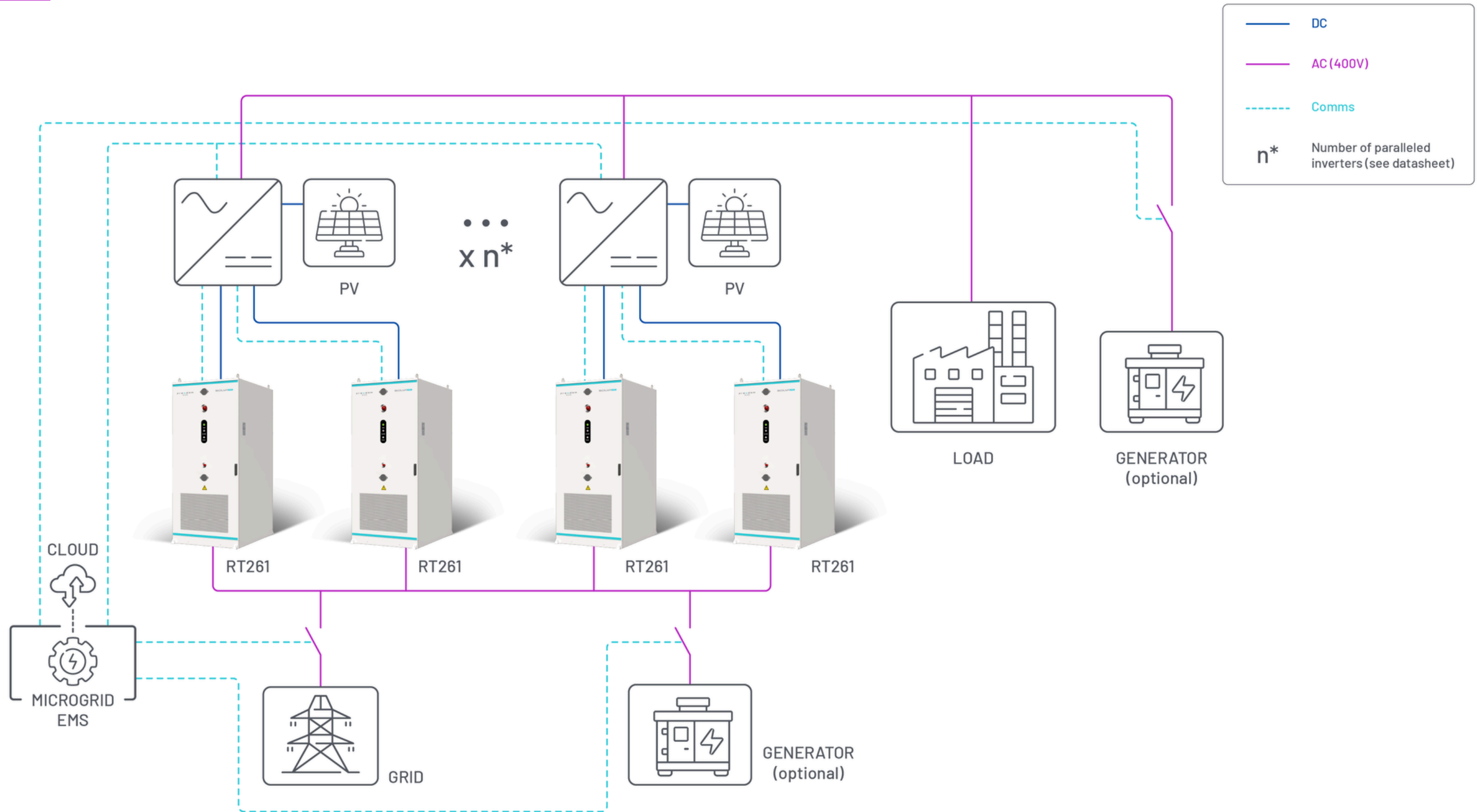

# SOLVA AC418

The SOLVA AC418 combines 418kWh LiFePO<sub>4</sub> battery storage, integrated PCS functionality and intelligent system control into a unified AC-coupled energy storage platform.

Designed for simplified deployment and scalable operation, the SOLVA AC418 supports on-grid and off-grid operation with parallel expansion capability for large-scale energy storage applications.

## Key Features

- Larger scale cabinet with built-in PCS.
- Optimal for systems that have MV ring main - Step-up transformer required.



Feature	Advantage
690V AC output	Compact high-power, high-efficiency PCS
Parallel scalability	On-Grid Expansion: 20 cabinets in parallel; Off-Grid Expansion: 8 cabinets in parallel
Power factor control	Active and reactive power capability
Robust PCS	Black start capability, built-in VSG, 50% inductive loads

**Standards & Certifications:**  
GB/T 36276-2023, IEC 62619, UN38.3

**Standard Warranty:**  
5 years (Warranty extension available)

## Specifications

<b>DC-SIDE PARAMETERS</b>	
Cell Capacity [Ah]	314
Battery Chemistry	Lithium Iron Phosphate (LiFePO <sub>4</sub> )
Total Energy Capacity [kWh]	418
System Depth of Discharge [%]	90
Nominal Voltage [V]	1331.2
Max/Min. Operating Voltage [V]	1497.6/1164.8
Cell Configuration	1P52S per module, 8 modules per pack
Battery Pack Thermal Management System	Liquid Heating and Cooling
<b>AC CONNECTION PARAMETERS</b>	
Integrated PCS rated power [kW]	215
System Output AC Voltage [V]	690 (-15% to +15%)
Rated Frequency [Hz]	50/60
AC Connection Method	(3P+N+PE) Three-Phase, Four-Wire System
Power Factor Range	Adjustable from 0.99 leading to 0.99 lagging
Total Current Harmonic Distortion (THD-I) [%]	<3 (at Rated Power)
Isolation Type	Non-isolated
AC Cable Entry	Bottom Entry
<b>LIQUID THERMAL MANAGEMENT</b>	
Power Supply	1/PE AC 220V 50/60Hz
Cooling Capacity [kW]	8
Heating Capacity [kW]	2
<b>SYSTEM PARAMETERS</b>	
System Total Efficiency [%]	≥88
Dimensions (H×W×D) ±5 [mm]	2550x1350x1350
Weight [Tons]	4.3
Ingress Protection	IP54
Corrosion Protection Class	C5
Inverter Thermal Management System	Intelligent Air Cooling
Monitoring and Control	Built-in Cabinet Monitoring System (CMS) interfaces with site EMS for coordinated control, monitoring, and logging of BMS, PCS, and thermal systems. Includes local data storage and cloud synchronisation for remote access.
Communication Interface	RS485 (EMS), CAN (BMS), PARA (STS), LAN (Network)
Parallel Configuration	On-Grid mode supports up to 20 cabinets in parallel. Off-Grid mode supports up to 8 cabinets in parallel.
Protection	AC overcurrent protection, AC overvoltage protection, AC short-circuit protection, anti-islanding protection, reverse polarity protection (DC side)
Fire Suppression System	Aerosol
<b>ENVIRONMENTAL PARAMETERS</b>	
Operating Temperature [°C]	Charging: 0 to 55; Discharging: -20 to 55
Operating humidity [%]	≤95
Max. Operating Altitude [m]	Full load up to 2000m; above that, derate 10% per 1000m up to 4000m

# System Architecture Diagram

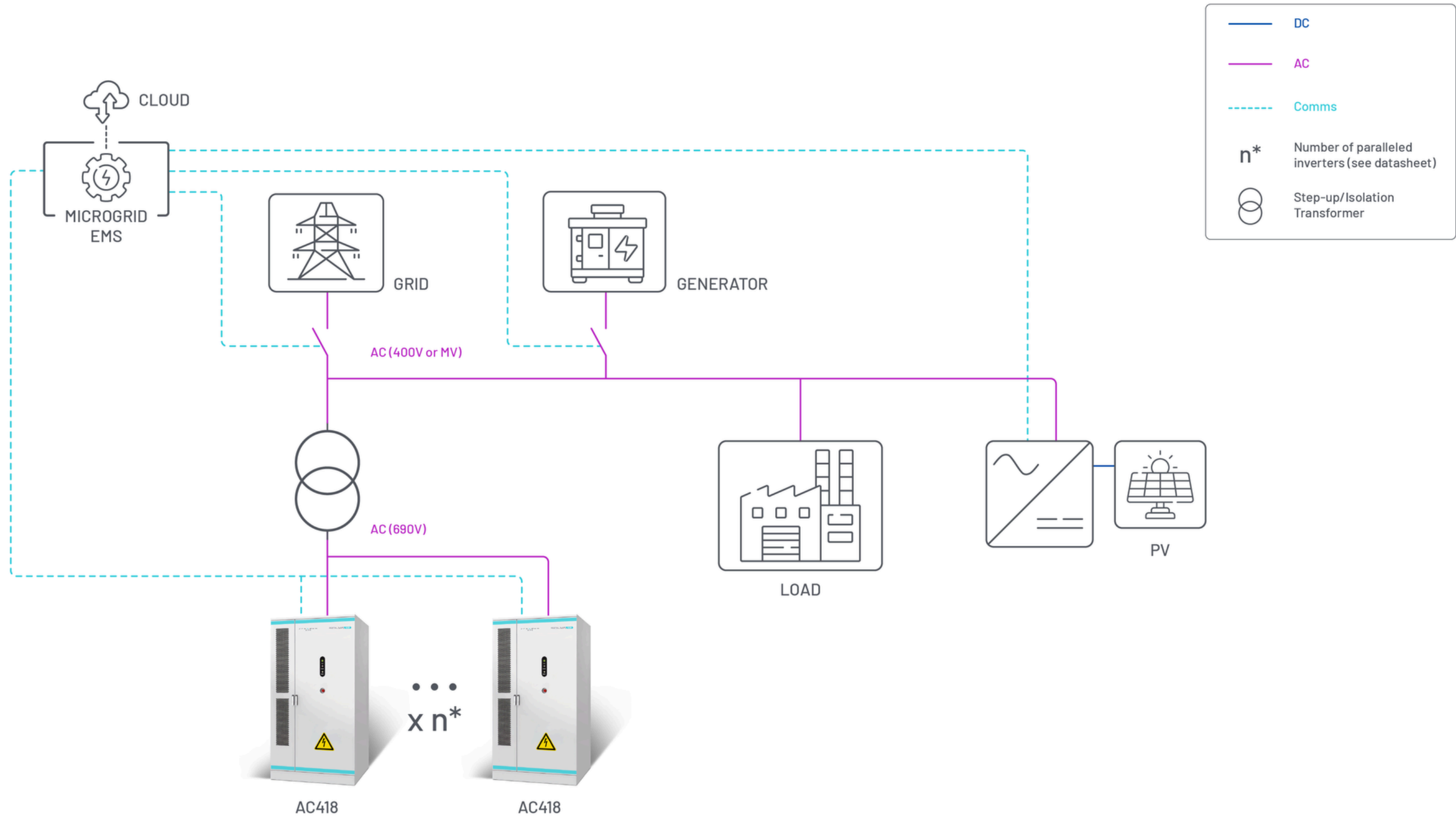

## SOLVA Range Feature Comparison

Specification	DC261	RT261	AC261	AC418
Coupling Type	DC-Coupled	Rectifier-coupled (AC Source)	AC-Coupled	
		DC-coupled (external inverter)		
Integrated PCS	No	Rectifier Only	Yes	
Nominal Voltage	832V			1331.2V
THD	N/A	<2%		
Power Rating	125kW (for 0.5C)	125kW		418kW
Parallel Capability	12 (DC Side)		20 (on-grid) / 8 (off-grid)	
Thermal Management	Liquid			
Protection Rating	IP55			IP54
Corrosion Rating	C5			



Give us a **call**

+27(0)10 597 7794



Send us an **e-mail**

enquiries@freedomwon.co.za



Find our **offices**

Longmeadow Business Estate  
Hereford Rd  
Modderfontein, Edenvale, 1609



Visit our **website**

www.freedomwon.co.za

FIND US ON:

