



Installation Manual

LiTE Home 52V

(Australian Market)

Range of Lithium Iron Phosphate Battery Modules

Manufactured By Freedom Won (Pty) Ltd

Hereford Rd, Longmeadow Business Estate,

Modderfontein, Edenvale,

1609

SOUTH AFRICA

www.freedomwon.co.za

Technical and Installation Assistance – Contact:

Please contact your Freedom Won Distributor or Reseller Installer for technical and installation support. A directory of Distributors and Reseller Installers is available at www.freedomwon.co.za.

For advanced support please contact support@freedomwon.co.za.

Update Record:

Revision Number	Update Summary	Updated By	Date of Issue
V1.0	First Release	Shawn Naidoo	03/12/2024
V1.1	Minor Updates	Antony English	01/05/2025

Contents

Manufactured By Freedom Won (Pty) Ltd	1
Technical and Installation Assistance – Contact:	1
1 Introduction	2
2 Product Description.....	2
3 DC Bus Design Notes	7
4 Transport, Handling, and Mounting.....	7
5 Mounting and Environmental Requirements	10
6 Connecting the Freedom Lite	11
6.1 Power Cables	11
6.2 Control Cables – Overview	11
7 CAN Bus Control – Detailed Description	12
8 Parallel Configurations.....	13
9 Grounding	15
10 Programming the LiTE unit.....	15
11 Startup and Shutdown Procedure	16
12 Settings Required for Configuring Inverters and Charge Controllers.....	17
13 Accessories	18
14 Typical Installations	19
15 Important Warranty Considerations.....	20
16 Expected Product Life	21
17 User Maintenance and Monitoring of the LiTE Battery.....	21
18 Troubleshooting Guide.....	22
19 Support	25

1 Introduction

This manual is designed to assist installers with the installation and commissioning of the Freedom Won LiTE lithium iron phosphate (LiFePO₄) energy storage modules. Installation must be performed by qualified personnel with the necessary professional skills and knowledge. This document does not cover detailed information about the internal workings of the LiTE energy storage modules that are not relevant to the installation and final commissioning process.

Additional information regarding the programming of the built-in battery management system for specific applications is available directly from Freedom Won to approved integrators. This manual does not cover all aspects of setting up third-party equipment in relation to the interface and functionality required to work with the LiTE energy storage modules. However, Freedom Won is available for direct support, as provided on page one, for supported inverter brands.

2 Product Description

Freedom Won batteries are available in a range of standard sizes to suit residential, commercial, and industrial applications, with models ranging from 7Ah 12V to 1475 kWh utility scale. For larger systems, Freedom Won provides solutions by installing multiple units of the same battery model in parallel, based on specific project requirements.

Freedom Won offers the following ranges in the LiFePO₄ technology:

1. LiTE 12V
2. eTower
3. **LiTE Home and Business 52V (this Manual)**
4. LiTE Home and Business HV
5. LiTE Marine
6. LiTE Mobility (golf carts, forklifts, etc)
7. LiTE Commercial HV and HV+
8. LiTE Industrial
9. megaTower Plus and megaTower Extra

This manual covers the standard voltage models of the **LiTE Home** range from 5kWh up to 30kWh. Please refer to the manuals specific to the other ranges as required.

The standard LiTE voltage is 52V nominal (to suit 48V systems). The LiTE HV range is designed for specific higher voltage inverters. The LiTE Commercial range varies from 52V to 800V depending on customer requirements (including the HV and HV+ models). The LiTE Industrial and megaTower models vary from 691V to 1152V depending on customer requirements.

The LiTE Marine range of lithium batteries is available upon request, offering specifications similar to the Home range, with 13V and 26V options to suit 12V and 24V systems, respectively. These models are water-resistant (IP65), designed for floor or horizontal deck mounting, and feature dimensions that differ from the LiTE Home models. For further details on these models, please contact Freedom Won.

Table 2.1 provides an overview of the 52V LiTE Home. There are four LiTE models in the Home range, as included in the table, classified in terms of energy capacity.

An image with numbered labels corresponding to the following paragraph is provided in Figure 2.1. The model number is structured as follows: the first number [1] represents the total energy storage capacity in kWh for each model. The second number [2] indicates the average amount of energy (in kWh) that should be withdrawn per cycle to optimize the lifespan of the lithium cells. This is typically 80% of the total capacity for each model, which corresponds to an 80% depth of discharge (DoD). Note that all Freedom Won LiTE batteries are designed to support a maximum of 90% DoD as standard.

The range is very compact, designed for standing on a level firm floor – all models are supplied standard with plastic feet).

The Ah capacity is also provided in the tables for each model for easy reference.

The maximum current for each model is governed by the rating of the built-in circuit breaker [3], which has been intentionally sized below the maximum current capability of the lithium cells. There is only a small cell temperature rise during normal daily cycle operation and no active cooling of the cells is required. The time limit for operation at the maximum current is 5 minutes every 10 minutes. To ensure that the circuit breaker does not trip in normal operation it is advised that the design of the system aims to operate at or below the continuous current value.

For the 52V models, the absolute maximum allowable voltage when fully charged is 56V. However, a more typical inverter charge setting range is between 55.5V and 55.8V, depending on the inverter's voltage tracking accuracy. The commonly used minimum cutoff voltage is 48V, although this is not typically reached when operating at 90% Depth of Discharge (DoD).

The Battery Management System (BMS) will command the connected inverter with a CAN Bus interface to stop discharging the battery when the State of Charge (SoC) reaches 10% (90% Depth of Discharge, DoD), which is approximately 49.0V. Under high load conditions, the voltage may temporarily drop to 48V while still above 10% SoC. In systems without a CAN Bus interface, or where the standby current draw from the inverter causes the battery to discharge below 10% SoC, a voltage of 48V or lower may be observed. To protect the cells from undervoltage, the battery breaker will trip at around 47V.

Figure 2.1 Labelled Image of the Freedom LiTE Home 15/12
(Labelling corresponds with the text)



1. Gross Capacity
2. 80% Capacity recommended for daily cycling (max available is 90%)
3. Breaker
4. Power Cables
5. CAN Bus Sockets x 2 (RJ45) (one socket must contain a termination resistor if end of line)
6. USB Programming Port (not visible in photo).
7. Reset Button (not visible in photo)
8. State of Charge / Error Light
9. On Button
10. Off Button
11. Lifting Eye Bolt Hard Point (not visible in photo)

The weight of each model is given in the tables. The unit weights must be carefully considered when planning an installation.

The dimensions given are for the principle outlines of the aluminium housing and exclude items that protrude such as the DC cable glands and the circuit breaker handle.

The DC cables exit the unit through glands located on the **top right-hand side** of the casing and vary in number according to the model [2 in Figure 2.1]. The correct cable lugs for connecting these leads to the inverter must be in hand when doing an installation. If several inverters and charge controllers need to be connected to the battery, it is advisable to install a DC connector box to use as a junction point from which to branch out to all the battery-connected equipment.

Table 2.1 LiTE Home 52V Range Overview

Freedom Won LiTE	Home	Home	Home	Home	Home
	5/4	10/8	15/12	20/16	30/24
Total Energy Capacity [kWh]	5	10	15	20	30
Energy, 80% DoD [kWh] (1)	4	8	12	16	24
Energy, 90% DoD [kWh]	4,5	9	13,5	18	27
Current Capacity [Ah]	100	200	300	400	600
Max & Cont. Charge Current [A] (2)	100	200	300	400	600
Max & Cont. Charge Power [kW] (2)	5	10	15	20	30
Max/Cont. Discharge Current [A] (2)	120/100	240/200	360/300	480/400	720/600
Max/Cont. Discharge Power [kW] (2)	6/5	12/10	18/15	24/20	37/30
Max Recommended Inverter Total Rated Power (cont.) [kVA]	8	10	15	15	25
Charge and Discharge Cutoff Voltages	Low Voltage: 46V, Upper Voltage: 55.8V				
Standard temperature range for charging	Lower Temperature: 0 Degrees Celsius / Upper Temperatures: 55 Degrees Celsius				
Standard temperature range for discharging	Lower Temperature: -20 Degrees Celsius / Upper Temperatures: 55 Degrees Celsius				
Nominal Voltage [V]	51.2Vd.c. to suit 48V Inverters, min 47V, max 56V				
Weight [kg]	49	89	130	173	245
Dimensions on or against wall - Height x Width x Depth [mm] (3)	500x340x290	745x340x290	745x490x290	745x640x290	1300x490x290
Enclosure	Aluminium – powder coated white front, rated for indoor use				
DC Connection - Integrated Cables, [no. per electrode] (4)	1x 50mm ²	1 x 50mm ²	2 x 50mm ²	2 x 50mm ²	2 x 95mm ²
Cell Connection Mode	1P16S (100Ah)	2P16S (100Ah)	3P16S (100Ah)	4P16S (100Ah)	6P16S (100Ah)
Control Interface	RJ45 Socket x 2 – CAN Bus for interfacing with compatible inverters and system controllers, and communication for the connection of parallel batteries – note that parallel batteries must all be of the same model.				

Protection	The Freedom Won Battery is equipped with Dual Shunt Trip Circuit Breakers that break both the positive and negative DC connection. The breakers are appropriately sized for the maximum current and can be triggered by the BMS in the event of a critical fault, requiring a manual reset. The system also incorporates comprehensive protection features, including overcurrent protection, cell under/over voltage monitoring, temperature regulation, weak cell detection, and minimum State of Charge (SoC) control.
Human Interface	State of Charge Display (0 to 100%), Error light, Error Reset Button, USB Plug for Programming
Warranty [5]	10 years or 6000 cycles for average 80% DoD, and max 90% DoD
Service Life [5]	16 years (>6000 cycles) expected life at 80% DoD (1)
Essential Accessories	Note that for connecting the battery to a PC a USB “printer” cable is required (one is supplied with each battery)
	CAN Bus Termination Resistor – one required per battery (one included with battery)
	CAN Bus Cable (RJ45 LAN Cable) – one required per battery (not supplied with battery). Note some inverters will require a special (non-standard pin configuration) cable – see installation manual
Authentication and Certification	UN38.3 / IEC62619:2017 / IEC61000-6-1:2019 / IEC61000-6-3:2021 / IEC62040-1:2017/AMD1:2021 Conformity / Clean Energy Council of Australia listed

Notes to Table 2.1

- 1) DoD = Depth of Discharge, recommended 80% DoD for average daily discharge, max for normal operation 90% DoD, max for system in standby 100% DoD.
- 2) Max current duration 5min every 10min. 1.5 x Max overload can be handled for 5 seconds. Current limits are rated for 10°C to 25°C battery temperature. Derating will apply outside this temperature range. For adherence to Standard Warranty requirements these current limits must be reduced to 0.25C for charge and 0.5C for discharge (C being the Ah capacity).
- 3) Dimensions on or against the wall excluding protuberances such as glands and breaker handles.
- 4) Fly Leads 1,8m long, power cable Red = Positive, Black = Negative, conductors in the table refer to one electrode i.e. per positive and negative connections.
- 5) End of Life (EoL) is defined as the cell dropping to 60% of Beginning of Life (BoL) capacity. This warranty applies to LiTE units sold after 1 April 2024. For LiTE units sold prior please contact Freedom Won for warranty information.

Two RJ45 sockets [6] are provided, one for connecting the CAN interface from the battery to the system controller or directly to the inverter depending on the brand, and another for connecting the battery to another battery or for a termination resistor (more detail later in the manual).

A USB Type B “printer” plug [7 - concealed] is fitted to the upper left-hand side of the housing for use by technicians for programming the required profile onto the BMS or updating firmware. The required profile is typically loaded by Freedom Won prior to delivery but installers are advised to obtain the correct cable to allow Freedom Won or the distributor to program batteries remotely on behalf of the installer via the installer’s Windows laptop, if necessary. One cable is provided with each battery.

An error reset button [8 - concealed] is positioned adjacent to the USB plug.

Figure 2.2 USB Type B “Printer” Cable for Programming LiTE units



The ON button [9] and OFF button [10] are located to the left of the SoC display.

A hard point is supplied on the top for the 15/12 and 20/16 models [14] for inserting an eye bolt that can be used for lifting the battery with a hoist. The LiTE 30/24 is supplied with a permanently installed eye bolt.

3 DC Bus Design Notes

The LiTE range includes two integrated battery DC breakers that break both the positive and negative cable continuity inside the battery (one breaker isolates positive and the other isolates negative). These breakers on all Home models, are rated for a 36kA fault (short circuit) current. An external isolation device can be installed as an additional safeguard aligned with battery installation best practices.

The approximate short circuit current values of each battery model are provided in the table below:

Table 3.1 Short Circuit Current for LiTE Home Models

Freedom Won LiTE	Home 5/4	Home 10/8	Home 15/12	Home 20/16	Home 30/24
Short Circuit Current [A]	1500	2100	3100	3600	4700

The external isolating device must be designed to withstand these fault levels (short circuit currents).

4 Transport, Handling, and Mounting

The Freedom Won LiTE units are packaged in protective layering and fastened into a wooden crate with pallet-type feet, which allow lifting with a forklift or a pallet jack. The LiTE Home 5/4 and 10/8 models are easily handled by two people. The LiTE 15/12 and 20/16 models may be manually handled by four or six people. The LiTE 30/24 model must be handled with care by a forklift or pallet jack of the required lifting capacity rating.

Eye bolts fixed to the top of the LiTE unit can be used for hoisting the battery into position if required (excluding LiTE 5/4 and 10/8, which can be lifted manually). The eye bolt on the models up to the LiTE 20/16 can be removed after installation. Ensure that you have one M12 x 1,75 thread eye bolt rated for 450kg or more for the models that are not supplied with permanently fixed eye bolts.

Lifting the batteries by the eye bolts should be performed using a mobile gantry crane or a high lift pallet jack.

Figure 4.1. Eyebolt Example



Figure 4.2. Eyebolt Installation on a LiTE 20/16 model (remove after installation)



The units can alternatively be lifted using a high-lift pallet jack such as shown in 4.3

Figure 4.3 High-Lift Pallet Jack.



Models up to LiTE Home 20/16 are fitted with lifting or maneuvering handles to make placement easier.

Caution:

1. *Handle the LiTE unit with great care when lifting and manoeuvring. It should remain either lying flat on its back or vertically upright (it should not be placed upside down or on its front face).*
2. *Do not allow the pallet jack to over-centre if it is a model with forks longer than the lower arms.*
3. *Take care not to knock any of the protruding items against obstacles during handling such as the DC cabling and plugs and the circuit breaker handle.*
4. *Take care not to scratch the unit during handling. Packaging foam should be used to protect the paint when being handled on a trolley or pallet jack.*
5. *Always ensure that lifting equipment and slings are adequately rated for the lifting weight.*
6. *Ensure that the eye bolts are fully screwed into the hard point thread on the top of the unit before lifting.*
7. *Wear personal protective equipment such as safety shoes and gloves while handling and mounting the LiTE unit.*

8. Always ensure that you have enough people on hand to operate safely, i.e. at least one person to guide and stabilise and one person to hoist or handle the pallet jack or gantry.

5 Mounting and Environmental Requirements

The LiTE Home models are designed strictly for indoor use away from moisture and direct sunlight.

No fresh air venting into the battery room is required because the LiTE unit emits no hazardous gases.

Air ventilation or air conditioning is however required to maintain the battery room temperature at appropriate levels, preferably below 25°C (see LiTE range warranty for information on upper temperature limits for hot environments). Ambient environments that regularly exceed 30°C should employ room cooling if practicable to ensure optimal service life.

Room heating may be required in cold climates to keep the room above 0°C – charging of the LiTE unit is not permitted below 0°C.

Temporary storage or transport of the LiTE unit is permitted in the range -20°C to 45°C, however extended storage should be between 0°C and 25°C.

The LiTE unit must be mounted on a level sturdy floor.

The LiTE must be positioned with a minimum 250mm spacing to other objects on either side, the top and the front. The gap between the battery and the wall should be 20mm.

Note that access is required to the USB programming port on the left side, and the CAN Bus plug sockets and cable exits on the right side.

The LiTE unit should be installed at least 1000mm way from a heat source or flammable substance.

The LiTE Home IP rating is IP20. The breakers are rated for IP40.

The LiTE warranty stipulates limitations of time allowed at various battery temperature levels. The installer or user is required to observe the battery operating temperature closely post commissioning by utilizing the data recorded on the inverter online monitoring platform (the LiTE transmits internal temperatures to the inverter over CAN Bus). If the battery is found to be spending excessive time within the time-limited temperature regions, the battery room temperature may need to be reduced, and/or the battery duty may need to be reduced.

A room temperature down to 18degC may be required for a battery operating at a high duty level.

Reduction of the battery duty is achieved by reducing the maximum charge current settings on the inverter and/or managing the system loads more efficiently. This might involve using more load during sun hours when the PV can contribute, and therefore lessen the load on the battery. The load profile can also be examined for opportunities to spread the load out more evenly over the day to avoid durations of particularly heavy demand on the battery. A larger or additional battery may be required to achieve the desired duty level.

6 Connecting the Freedom Lite

6.1 Power Cables

The LiTE unit is simple to connect to the inverter. First of all, you will connect the 48V positive and negative cables to the inverter terminals using the applicable lugs.

Caution: Prior to connecting the positive and negative cables to the inverter be sure to check that the main battery circuit breaker is switched off. This will ensure that there are no short circuits between the loose ends of the cables.

The cables are supplied with the LiTE unit, permanently fixed into the unit, and secured onto the casing using compression cable glands.

Attach crimp lugs to the ends of both cables ensuring that the correct terminal size is used, and the lug is matched to the size of the cable. The positive cable is red, and the negative cable is black. This is confirmed by + and – signs on the battery casing beside the respective cables. See Table 2.1 for the cable size and quantity fitted to each LiTE unit. The cable cross-sectional area is based on an acceptable voltage drop with the inverter being mounted on the wall adjacent to the battery so that the cable run is less than 5m (Note: however, the standard cable length is 1,8m, longer cable available on request).

Cable runs longer than 5m should be assessed and larger cables considered for extending the LiTE unit cables to minimise voltage drop. Double Insulation copper cable is recommended.

The cables may be routed through trunking and connected to the inverter on the positive and negative terminals respectively. The inverter terminals on some inverters can then be used for linking up separate charge controller(s) to the DC Bus. On Installations where there are too many inverters and/or charge controllers to connect to the DC bus using the inverter terminals as a junction point, a DC connector box is required. Where multiple cables are fitted per pole, the cables for each pole are connected together inside the battery. All cables for each pole must be routed to the same location.

6.2 Control Cables – Overview

For controlling external devices, you will need to connect the CAN Bus cable that allows the BMS inside the LiTE unit to control and interface with these devices.

The CAN Bus connection is made using the RJ45 plug with the pin configuration on the battery plug end is provided in Table 6.2.1.

Table 6.2.1 Colour Coding and Pin Configuration for CAN Bus UTP Control Cable

RJ45 Pin No.	Standard Ethernet Cable Colour	Wire Function
Pin 1	Orange/White	Not connected
Pin 2	Orange	Not connected
Pin 3	Green/White	Not connected
Pin 4	Blue	Not connected
Pin 5	Blue/White	Not connected
Pin 6	Green	Not connected
Pin 7	Brown/White	CAN High
Pin 8	Brown	CAN Low

Please refer to the respective inverter brands manual for their pin configuration or contact Freedom Won for assistance.

7 CAN Bus Control – Detailed Description

CAN is a widely used communication protocol in systems that involve multiple devices needing to report their status or send commands to others on the same network. The LiTE unit BMS can transmit messages and commands using the CAN protocol to provide information to, and more importantly, control external devices. CAN offers significant versatility and enables simple installation, requiring only two wires for communication: CAN High and CAN Low.

For an inverter or charge controller to be controlled via CAN, it must first be equipped with a CAN interface and a suitable method for connecting the CAN wires. Additionally, the LiTE unit's Battery Management System (BMS) must be programmed with a CAN messaging profile tailored to the specific inverter or charge controller being used. This profile must be developed individually for each inverter model or model range. To date, Freedom Won has developed CAN profiles for most common inverter brands on the market, details are available in the Freedom Won Inverter Compatibility Guide.

Freedom Won welcomes requests to develop BMS CAN profiles for additional inverters that are equipped with a CAN interface for BMS integration.

The CAN interface can provide the following functionality to compatible devices:

- i. Charge Current Limit of all LiTE units connected
- ii. Discharge Current Limit of all LiTE units connected
- iii. Actual State of Charge (minimum of all LiTE units connected)
- iv. Actual Battery Temperature (highest of all LiTE units connected)
- v. Actual Voltage
- vi. Actual Current (total of all LiTE units connected)
- vii. Maximum real-time charge voltage setpoint
- viii. Battery Name
- ix. Highest Cell Voltage of all LiTE units connected
- x. Lowest Cell Voltage of all LiTE units connected
- xi. Firmware Version
- xii. Ah capacity of all LiTE units connected
- xiii. Advanced communication between all connected LiTE units

The CAN 2.0 Part A and Part B standard uses the SAE J1939 standard in the LiTE unit. It is necessary to install a 120Ω resistor on each end of the CAN cable (splices do not require a resistor). Most devices operating on CAN have two plugs to connect in and then out again on the CAN Bus. The first and the last device in the chain must have a termination resistor plugged into the spare (second) plug. The LiTE unit resistor plugs are available from the inverter manufacturer and from Freedom Won. Where one LiTE unit is installed or where it is the end-of-line CAN device, **the LiTE unit must be fitted with a termination resistor.**

The LiTE unit is supplied with a termination resistor as standard. Other devices must be equipped with the correct termination resistor for that specific brand, as the pin configuration may differ from the battery plug.

The third-party device manuals must be referenced for all details regarding connecting the CAN interface.

Most brands use 500kbps. If 250kbps is required, it is available on LiTE units with a specific profile loaded, which must be requested when ordering the unit or can be loaded during commissioning by your distributor for Freedom Won technical support.

If you did not purchase a CAN Bus cable to suit your inverter you can make your own according to the required pin configuration. Fig 7.1 provides the standard colour coding for an ethernet cable (note that there are other variations.).

Fig 7.1 Pin Configuration for standard Type T-568B RJ45 plug



If your inverter is not included in this table, please contact Freedom Won for assistance.

8 Parallel Configurations

Multiple LiTE units can be connected in parallel, provided that the model size is the same across all units. However, it is generally more cost-effective to purchase a single larger LiTE model rather than connecting multiple units in parallel. This configuration is typically used for future expansion, particularly when it is not feasible to purchase a sufficiently large model upfront due to financial constraints.

The LiTE batteries configure themselves automatically once they are switched on, with the first battery that is switched on assuming the role of the “master”. All others to be switched on subsequently assume the role of “slaves” by automatically assigning themselves with unique addresses. A maximum of 20 units can be connected in parallel.

All the LiTE units must be connected onto the CAN Bus via the CAN Bus using standard LAN cable.

When using the CAN Bus to control the inverter(s) and charge controller(s), the CAN Bus from any battery can be connected directly to the inverter or the system controller, depending on the

product brand. The LiTE is equipped with two RJ45 sockets (refer to Figure 8.1.). On the last unit in the cable connection line, one socket is used for an end-of-line (termination) resistor, with the second RJ45 being used to connect to the next device, whether it be another battery, an inverter, a solar charge controller, or a system controller. On a unit connected in the communication line, both sockets are used to connect to other equipment. This connection method is referred to as a "daisy chain".

Figure 8.1. Picture Showing 2 x RJ45 Sockets for CAN Bus Figure 8.2. Picture Showing 2 x RJ45 Sockets for CAN Bus



Figure 8.2. CAN Bus Connection Example with Four LiTE Units

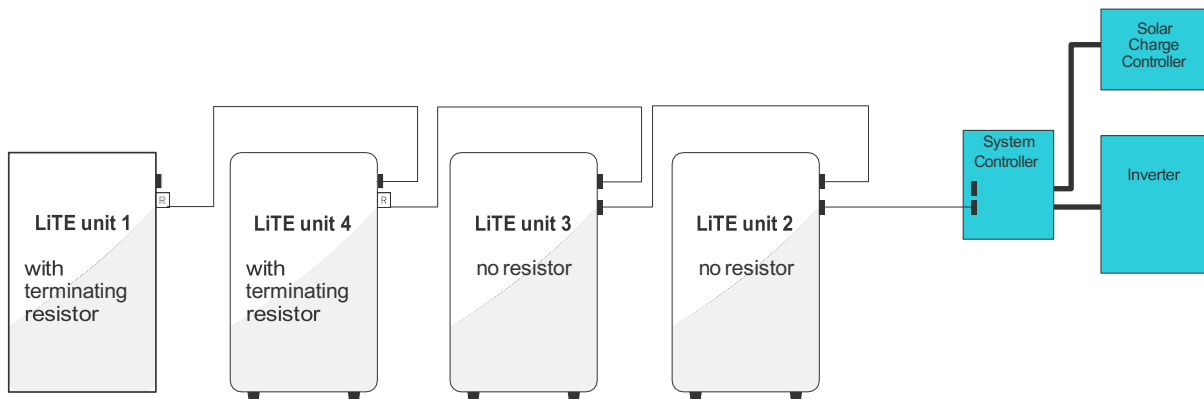

If the master LiTE unit trips, one of the slaves will take over as the master automatically, without any interruption of service.

Freedom Won offers a fair trade-in on LiTE units on the purchase of new units, which is an option for somebody wishing to expand their battery capacity instead of installing parallel units. Please request more details from Freedom Won if this is your upgrade preference.

New units can be placed in parallel with old units up to about 4 years or 1 500 cycles, after which it is preferable to trade in for a new larger unit.

9 Grounding

Correct grounding of the LiTE casing is essential. If the LiTE is not properly grounded, it may lead to CAN Bus communication issues.

Correct grounding also provides a safe path for stray or excess electrical current, reducing the risk of electrical shock caused by unexpected voltage spikes. A dedicated grounding sticker is provided on the casing to ensure the frame illustrates the correct grounding position. Ensure the frame is always grounded at this designated point, as shown in Figure 9.1 below.

During installation, the installer must remove the screw at the indicated grounding point and use the same screw point to attach a grounding cable fitted with a crimped ring terminal to suit the M5 screw diameter. The grounding cable should be correctly colour coded (green and yellow) and of 16mm² cross sectional area. The cable must be securely connected to the protective earth on the premises.

Figure 9.1. Picture Showing the grounding sticker on the casing.

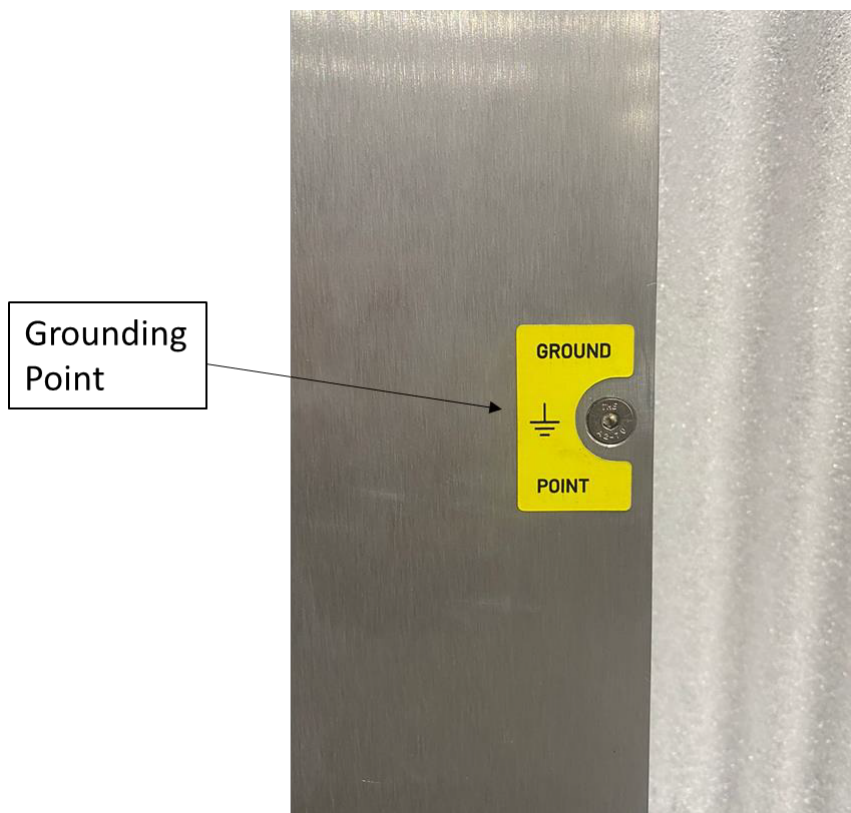

10 Programming the LiTE unit

The serial USB port on the left-hand side of the LiTE unit is used for configuring the BMS profile. The USB cable required to connect the LiTE unit to a computer is supplied with the battery. The computer must be windows based and have the correct utility software installed. Programming the BMS is intended to be performed solely by Freedom Won or approved distributors and installers. Write access to the BMS profile is password protected; however, users and owners can request read-only access.

The LiTE must be programmed with the correct settings profile to match the inverter to be used. The most important aspect of this profile is the correct CAN Bus communication protocol for the inverter to be used. Most inverters on the market are compatible with the Freedom Won LiTE Home range using the standard factory

settings profile, but the installer should reference the Freedom Won Compatibility Guide to make sure.

Correct CAN Bus communication is crucial to the reliable operation of the system and the ability for the inverter to obtain data from the battery for presenting into the monitoring portal. The availability of monitoring portal data is essential for the ongoing system monitoring, including verification that the battery is being operated according to the warranty requirements and the user manual recommendations in terms of peak current (power) levels and temperature.

11 Startup and Shutdown Procedure

The LiTE unit is fitted with an “ON” button. Press this button for at least 5 seconds to switch on the BMS inside the battery. Once the BMS has been energised you will observe the SoC display come to life with the SoC level shown. Confirm at this stage that the error light is not illuminated. If it is, contact Freedom Won. If the Reduced Power light is illuminated, do not be concerned, it should turn off automatically after the battery has been in operation for a few hours.

Once the BMS has been energised, both the main breakers may be switched on by pushing the breaker upwards. Ensure beforehand that you have secured the DC cables to their proper locations and that the rest of the system is ready to receive battery voltage. If the breaker is in the tripped position it will be necessary before lifting the breaker to first push down the breaker lever to reset the internal mechanism.

Note: Some inverters experience a large inrush current when switching on the DC supply. In such cases, it is important to pre-charge the DC bus. For most inverters, this can be done by switching on the PV to the MPPTs, allowing them to apply voltage to the DC bus before closing the battery breaker. This will only work when during the day when PV is being produced. If this option is not available, you can switch on the AC input power to the inverter, which for most inverters will place voltage on the DC bus. For inverters that do not have this capability, a pre-charge resistor will be required.

To switch off the DC output from the LiTE unit, pull down the breakers. To disconnect power to the BMS, press the “OFF” button located to the right of the “ON” button. This will also trip the breaker if it is still in the "ON" position. The LiTE unit must be fully powered off when not in use to prevent self-discharge.

Fig 11.1 “ON” and “OFF” Buttons – Breakers shown in OFF position



If the system is to be shut down for maintenance the battery breakers should be placed in the off position as described above and if external fuses, isolators, or circuit breakers are fitted to the battery cables, these should also be moved into the off or isolated position.

12 Configuring Inverters and Charge Controllers

The Freedom Won LiTE batteries are designed to operate with a CAN bus compatible inverter. The CAN Bus allows the battery to transmit limits and data. This means there are few parameters that need to be set into the inverter during commissioning.

The data transmitted from the battery to the inverter is recorded by the inverter's online monitoring portal if correctly set up. It is important to ensure that this is done correctly during commissioning and that the portal is checked regularly to ensure the inverter is still online and data is being uploaded to the portal regularly and reliably. A good Internet connection is crucial for correct system monitoring.

Some inverters require a specific setting to enable "Lithium Ion", and some require the correct Lithium Ion "Type" to be selected. The Freedom Won Compatibility guide provides guidance on the setup required for the inverters supported by Freedom Won.

Some inverters allow setting limits for charge and discharge current, and for maximum and minimum voltage. Most include a setting for the minimum allowed State of Charge (SoC) that will be allowed while the grid is available. There is also usually a lower SoC threshold that will start a generator along with an upper SoC threshold that will stop the generator.

If these parameter fields are present, set according to the following:

- Charge Current Limit – For optimal performance set to the maximum continuous charge current value provided in the specification sheet for the applicable model (see Table 2.1). For optimal battery longevity, and adherence to the Standard Warranty, the maximum charge current should be set to 0,25C. The C represents the Ah of the battery as per the data sheet. For a 100Ah battery (the LiTE Home 5/4) for example, the formula is as below:
 - Maximum Charge Current of 0,25C = $0,25 \times 100 = 25A$
- Discharge Current Limit – The discharge current is determined by the loads at any given time, and is only limited by the maximum rating of the battery inverter. For optimal performance the inverter and loads may be sized according to the maximum performance of the battery as per the data sheet. For optimal battery longevity, and adherence to the Standard Warranty, the maximum discharge current should be limited to 0.5C. This is achieved by ensuring that the load connected to the battery inverter will not exceed this value, or by selecting a battery inverter and battery combination where the battery inverter cannot exceed 0.5C for the battery. If the battery inverter can exceed 0.5C and there is a risk that the loads may reach this level, a larger or additional battery should be added to the system if adherence to the Standard Warranty is desired. Alternatively the battery may be operated at a duty that pertains to the Alternate Warranty. For a 100Ah battery for example, the formula for determining the 0,5C current is as below:
 - Maximum Discharge Current of 0,5C = $0,5 \times 100 = 50A$
- Maximum charge voltage for float and absorption – set to 55.8V
- Minimum voltage – set to 49,0V
- Minimum SoC while grid is available – Recommended value is 20%, although the installer or user may elect to use a higher value to ensure adequate energy is retained for a grid outage.

- Generator Start SoC – Recommended value is 15%, although a higher value may be desired to suit specific operational requirements. The stop value should be set somewhere around 50%. Setting the stop value to 100% is suggested for off grid systems with insufficient solar power to fully charge the battery. This is to ensure that the battery gets calibrated at the top point regularly.

13 Accessories

Freedom Won offers the following accessories:

Table 13.1 List of Accessories

Item	Description
120Ω Termination Resistor - RJ45	For plugging into the second CAN port for an end-of-line Battery (these are supplied with each battery and hence it is generally not necessary to purchase separately from Freedom Won.
Eye Bolt M12	Required for lifting 15/12 and 20/16 models using the hard point on top of the unit
CAN Bus Cables	For various inverters requiring non-standard cables. These can however be made up by the installer to the required pin configuration.

14 Typical Installations

Below is a diagram of a typical battery and inverter installation.

Figure 14.1: Typical Installation

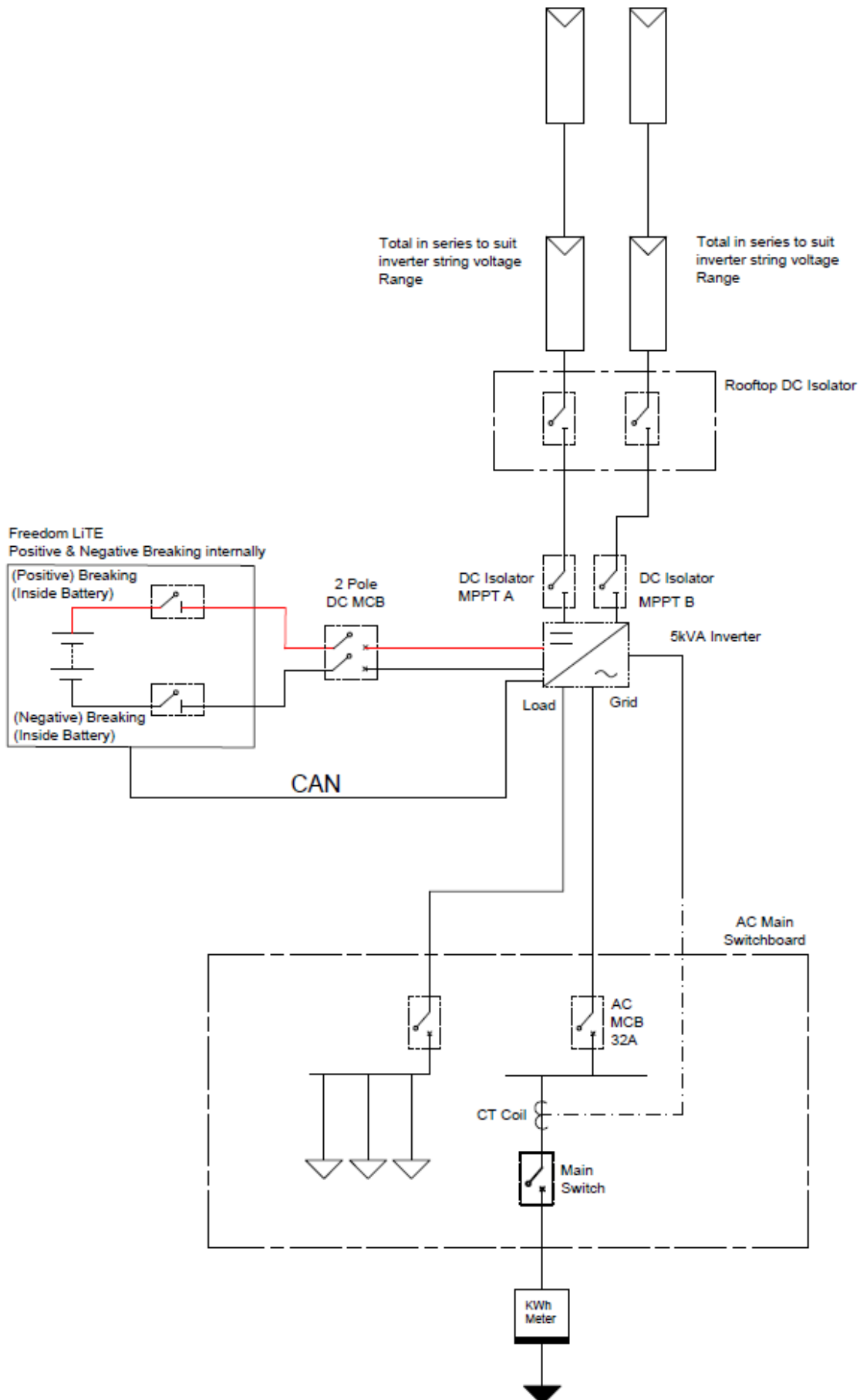

Note the two pole DC MCB (or other type of isolating device) shown on the cable connection between the battery and the inverter may not be required considering that the battery breaks both the positive and negative poles internally when the two circuit breakers are switched off. The decision whether to install an external isolating device is left to the installer.

For assistance with connecting and configuring the supported inverters, please contact Freedom Won Technical Support if needed.

15 Important Warranty Considerations

The LiTE unit is sealed with a tamper proof warranty seal. It may not be opened by anyone other than Freedom Won and installers or repairers that have been explicitly approved by Freedom Won. The warranty on the unit will be void if the seal is damaged or missing.

If the LiTE unit indicates an internal problem, please contact Freedom Won or the installer that installed the system. Freedom Won will arrange that it is inspected and repaired.

The warranty will not cover damage to the control wiring resulting from draw of excessive current or any damage resulting from lightning. Damage caused by physical means to the battery housing, external and internal fittings, such as impact with other objects, or being dropped, is not covered by the warranty.

The standard warranty period covers 10 years or 6 000 cycles at an average of 80% DoD, whichever should first occur. The battery is required to provide at least 60% of its new capacity at the end of this period or cycle count. A linear degradation from 100% to 60% is assumed, however the warranty makes no guarantee as to the shape of the degradation curve during the warranty period.

The standard warranty has specific restrictions on the duty and operational factors relating to the battery that are more restrictive than the maximum performance capabilities described in the data sheet. An alternate warranty is described in the warranty document that may be applied for operation without these restrictions.

The specific restrictions that must be considered to ensure operation that maintains the validity of the standard warranty pertain to the maximum allowed charge and discharge current levels, and to the battery temperature profile over time. For further details pertaining to ensuring use within the temperature restrictions applicable to the standard warranty please refer to Section 5.

The BMS records the number of cycles used. If you suspect that your LiTE unit is delivering substantially below its minimum performance of 60% capacity, please contact Freedom Won for an investigation. If the unit is found to be underperforming it will be serviced or replaced with a similar battery or batteries such that the minimum performance guarantee is again restored. Freedom Won may arrange for an on-site service or for collection of the unit for servicing at our facility. This will be mostly determined by the geographic location, ease of access to or removal of the unit, and size of the unit.

The LiTE battery must be installed by an approved installer to ensure validity of the warranty. Enquire with the applicable distributor or with Freedom Won Australia through the contact details available at <https://www.freedomwonaustralia.com/where-to-buy/>.

For more detailed warranty information please contact refer to the Freedom Won LiTE Warranty document.

16 Expected Product Life

LiTE models are designed for optimal life cycle cost, LiTE models are expected to operate for about 16 years in a daily cycling scenario for more than 6000 cycles. The defined end of life in this instance occurs when the battery capacity falls to 60% of the new capacity.

To ensure optimal product lifetime it is essential to cycle the battery regularly. Battery degradation is worse if kept at full charge for long periods, so the control settings on the inverter should aim to keep the battery full for less than three hours per day. The restrictions provided for the Standard Warranty must be strictly observed to achieve long life. Refer to the Freedom Won LiTE Warranty document for further information.

17 User Maintenance and Monitoring of the LiTE Battery

While in Storage – Ensure that the battery is kept in a cool dry place and away from a corrosive atmosphere such as sea air. The temperature of the storage area should ideally be 20-25degC, however 0-25degC is acceptable. The battery must be retrieved from storage every 6 months for a conditioning charge and discharge cycle. First charge the battery to 100% SoC and to the applicable float voltage (max 55.8V if possible). Then discharge the battery to 50% SoC before returning to storage. Operate the charge and discharge current at less than 0.25C.

While in Operation – Check every six months that the system is operating optimally. These checks include:

- Confirm through access to your inverter online monitoring portal that the battery receives a full charge at least every 3-5 days. Full charge means 100% SoC is reached, but also requires that the float voltage is reached.
- Confirm through your inverter online monitoring portal that the cells on the battery are reasonably well balanced. This means the cell voltage spread when the pack is floating should not display a cell higher than 3.65V or lower than 3.37V. If the cells are out of this range, the battery should be operated such that it spends more time at float charge to allow the BMS to catch up on its balancing function.
- Confirm through the data available on your inverter online monitoring portal that the temperature of the battery seldom exceeds 30degC, and that it is mostly operating at 25degC. Confirm that the battery does not operate below 0degC. In general confirm that the temperature data adheres to the applicable warranty stipulations (Standard or Alternate Warranty as applicable).
- Confirm through the online data from the inverter monitoring portal that the current in charge and discharge remain below the limits stipulated for adherence to the applicable warranty stipulations (Standard or Alternate Warranty as applicable). Specifically for the Standard Warranty the charge should not exceed 0.25C and the discharge should not exceed 0.5C.
- Check all cables and connections external the battery for evidence of heating and corrosion. Replace corroded parts. Check bolt or terminal tightness if heating evidence is observed. If loose connections are discovered contact your installer for assistance with tightening and checking all connections.
- Cleanliness: Keep the battery and surroundings free of dust and debris,

which can affect heat dissipation. Clean with a soft, dry cloth; avoid water, organic solvents, or synthetic fabrics

- Inspect the battery casing for any evidence of electrolyte leakage. If leakage is detected contact your installer.
- Inspect the battery casing for physical damage that may have occurred from impact or other mishandling. If dents or deformities are discovered, contact your installer.
- Should there be any concern about the safety status of the battery, the battery should be shut down and isolated by first switching off the battery by pressing the OFF button, and then ensuring the circuit breakers have tripped to the off position as a result. Should either have failed to trip, press the lever down manually. If there are externally mounted fuses or circuit breakers on the battery DC connection, these should also be opened to provide further isolation of the battery from the rest of the system. Call your installer for further assistance.

18 Troubleshooting Guide

Most issues with the LiTE unit can be resolved by following the guide below. If the issue persists after referencing the table, please contact Freedom Won or your authorized Freedom Won supplier for further assistance.

Table 20.1 Troubleshooting Guide (applicable to units with On and OFF buttons)

No	Problem Description	Cause/Solution
1	The LiTE models have no voltage on the main output cables	Check that you have switched on the main breaker switch. Note – only turn this on once you are satisfied that you have completed the installation and that there are no DC or control wires that can short out or touch ground or other wires. Also ensure that you are ready to accept AC voltage onto the inverter output before switching this breaker on. Also confirm that you have energised the BMS first by pressing the “ON” button for 3 seconds and as evidenced by the lights on the SoC display. If voltage is still not present with the breaker switched on it is possible the breaker has been damaged – please contact Freedom Won.
2	The BMS (indicated by battery SoC display lighting up) does not stay on after the ON button is pressed	<ol style="list-style-type: none"> 1. Error on the BMS. Check whether the red error light is illuminated on the SOC display when the ON button is held in. You can try to reset the error by pressing the RESET button for about 2 seconds and release. This should clear the error and allow the BMS to stay on after releasing the ON button. 2. Battery has been discharged to critically low level – remove all potential loads from the battery and switch off the inverter(s). Then try to switch on the BMS. Battery has been charged to critically high voltage level – 3. usually leaving the battery for an hour will allow the cell levels to drop down within the acceptable levels and allow the BMS to be switched on again. 4. If the BMS still does not switch on, please contact Freedom Won or Authorised Distributor.

<p>3</p>	<p>The main breaker switch keeps tripping each time I attempt to switch it on</p>	<p>There are several potential causes:</p> <ol style="list-style-type: none"> 1. The BMS has not been switched on. The ON button must be pressed for 5 seconds. On release the SoC Display must remain illuminated. 2. High inrush current on certain inverters – First preference is to pre charge the DC bus by switching on the solar charge controllers if present and in daytime. If this is not possible switch on the AC feed into the inverter and switch on the inverter. Some makes will then pre-charge the DC bus. You can also use a pre-charge resistor for this. If this does not work after the second attempt investigate the other options. 3. Short circuit on the DC Bus or faulty inverter or MPPT causing high currents. 4. In a system with multiple LiTE units in parallel, the reason could be that the unit you are trying to switch on is at a different voltage to the others – the voltages must be similar (within 1V of each other) on all batteries when switching them onto a common DC bus. <p>If none of the above solve the problem, you will need to contact Freedom Won or your authorised installer for assistance with this issue.</p> <p>It will be necessary to establish the reason for the error before continuing with normal operation of the system. Repeated tripping is damaging for the breaker.</p>
----------	---	--

4	After resetting the BMS the main breaker still will not stay up	<p>The is most likely because the battery is fully discharged and the BMS is protecting the cells from further discharge. Ensure that there is no chance of load being applied to the battery by isolating the AC output from the inverter. Ensure that the AC input to the inverter is live so that the charger may begin charging the battery after you switch it on. Alternatively, an MPPT can be used for this immediate charge if there is sunshine at the time. This charge should increase the battery voltage to prevent further tripping. This problem should not occur if the inverter control is working properly.</p> <p>If this does not work, it is because the battery has been discharged too deeply and will need to be reset remotely by Freedom Won by accessing your Windows PC connected to the battery. The PC must have TeamViewer installed and you will need the RS232 adaptor to connect the PC to the battery. Please contact Freedom Won.</p>
5	I have switched off the main battery breaker switch to prevent discharge of the battery but the SoC display lights are still on	<p>The BMS and SoC display receive power directly from the battery and therefore the "OFF" Button must be pressed to switch off the internal electronics.</p>
6	The inverter will not come on even though the inverter switch is selected to 'on'	<p>The enable command may not be coming from the BMS or may not be properly connected to the inverter or the inverter may not be properly configured to deal with the enable command.</p> <p>If you are running on a CAN Bus control with a compatible inverter and you are not observing the correct enable response from the inverter check that the CAN High and CAN Low wires are connected properly (ensure that you have the High and Low the right way around and that you have connected the two end of line 120Ω resistor in the applicable places. If this is not the problem then you need to confirm that you have the right CAN profile programmed onto the BMS for the inverter in use (baud rate or CAN messages may be for another inverter brand) or that you have configured the inverter or system controller correctly. Check that your CAN Cable is properly made up on the pin configuration and that the terminations are good. Contact Freedom Won or your Authorised Distributor for assistance.</p>
7	The charger will not come on even though there is power on the AC input of the inverter and the charger is activated in the inverter settings	<p>The battery might be full. Try discharging the battery for a while and observe if the charger then comes on. If not, then the fault finding process is similar to above.</p>
8	The error light keeps illuminating after each reset	<p>If the battery voltage is within limits this should not ordinarily occur. Contact Freedom Won or an approved installer for assistance with determining the problem. If the main breaker does not trip it is not a critical error and you may continue using the battery while you make contact for assistance.</p>
9	The pack voltage is within limits, but the main breaker still trips seemingly at random	<p>This could be caused by many things but is most likely because the current draw is exceeding the battery current limit setting. Measure the current with a tong tester while drawing your maximum typical load to determine if you are exceeding the rated current for the respective LiTE model. If it is not the current causing the trip it could be a weak cell or extreme temperature of the surroundings. Both are unlikely. If the problem persists, contact Freedom Won.</p>

19 Support

Use the following contact details to make inquiries on technical matters or for actual technical support with design and/or commissioning **pertaining to units sold in Australia, New Zealand and all other countries of the Oceania region:**

Attention: Dan Nel or Hennie Coleman

Mobile: +61 499 408 975 or +61 477 304 101

Email: support@freedomwonaustralia.com

Support System to log a ticket online: <https://freedomwonaustralia.samanage.com/login>

Note: first visit to the support – register and then log a ticket.

Physical Address:

Stalwart Energy Australia Pty Ltd (ABN 17 132 808 694)

U220, 17 Partridge Ave

Castle Hill

2154, NSW

www.freedomwonaustralia.com