



# Installation and User Manual

## Freedom Lite Commercial

52V and HV Models

*Lithium Iron Phosphate Batteries*

Manufactured By Freedom Won (Pty) Ltd

*Longmeadow Business Estate*

*Nguni and Hereford Rd*

*Modderfontein, Edenvale*

*1609*

*South Africa*

[www.freedomwon.co.za](http://www.freedomwon.co.za)

Technical and Installation Assistance – Contact:

Please contact your Freedom Won Distributor or Reseller Installer for technical and installation support. A directory of Distributors and Reseller Installers is available at [www.freedomwon.co.za](http://www.freedomwon.co.za).

For advanced support please contact [support@freedomwon.co.za](mailto:support@freedomwon.co.za).

Update Record:

Revision Number	Update Summary	Updated By	Date of Issue
3	Incorporated new model names and warranty to reflect guaranteed performance at 80% average DoD	Antony English	28 April 2020

## 1. Introduction

This manual is intended to assist an installer for the installation and commissioning – and to the user for the operation of – the range of **Freedom Lite Commercial** lithium iron phosphate (LiFePO<sub>4</sub>) energy storage modules manufactured by Freedom Won. This document is not intended to provide detailed information of the inner workings of the Freedom Lite beyond the scope of installation, commissioning and the ongoing use of the product.

Supplementary information relating to programming of the built-in battery management system for specific applications is available to approved integrators directly from Freedom Won.

This manual does not attempt to cover all the details pertaining to the setup of third-party equipment in relation to the interface and necessary functionality to work with the Lite. Freedom Won however is available at the contact details on page one to provide direct support where necessary for supported third party brands.

## 2. Product Description

The Freedom Lite technology is available in various standard sizes to meet all residential, commercial and industrial applications ranging from 5kWh up to 2500kWh. Even larger systems are provided by Freedom Won based on specific project requirements by installing multiple units in parallel.

Freedom Won offers the following ranges in the LiFePO<sub>4</sub> technology:

1. Lite 12V
2. Lite Home and Business
3. Lite HV Home and Business
4. Lite Marine
5. Lite Mobility (golf carts, forklifts etc)
6. **Lite Commercial (including Lite Commercial HV and HV+)**
7. Lite Industrial

This manual covers the **Lite Commercial** range from 100kWh up to 700kWh. For information specific to the other ranges please refer to the applicable manuals. The Lite Commercial range offers world leading levels of power output for the respective battery capacity with an extremely robust and advanced system architecture. Furthermore, the cost vs performance of this range is world leading.

The Lite Commercial range is available in a voltage of 52V nominal (to suit 48V systems). The Freedom Lite Commercial range is also available in higher voltages to suit specific high DC voltage inverters and is referred to generally as the Lite Commercial HV and HV+ range. The Lite Commercial HV and HV+ range is available in various nominal DC operating voltages up to 800V depending on customer requirements.

Table 2.1 provides an overview of the 52V Freedom Lite Commercial range. There are ten Freedom Lite models in the 52V Commercial range, as included in the table, classified in terms of energy capacity.

The Commercial HV and HV+ range is predominantly provided in the voltage option to suit the most common inverter pairing i.e. 512V DC for the ATESS HPS hybrid commercial inverter and 576V DC (or higher) for the ATESS PCS industrial inverters. Up to 800V DC nominal for the Ingeteam 1MW class and SMA 2MW class battery inverters and other similar battery inverters is also available. Refer to Table 2.2 for the HV and HV+ model options to suit the ATESS inverters. Please contact Freedom Won should specific technical information be required for the models suited to the Ingeteam 1MW class and SMA 2MW class battery inverters and any other brand of high DC voltage battery inverter.

An image with numbered labels pertaining to the following paragraphs is provided in Figure 2.1. The model number denotes with the first number [1] the total energy storage capacity in kWh of each model. The second number [2] denotes the average amount of energy in kWh that should be withdrawn per cycle (on average) in order to optimise the life of the lithium cells. This equates to 70% of the total for each model i.e. 70% depth of discharge (DoD). **Note that all Freedom Lite batteries offer a maximum of 90% DoD as standard.**

The range is designed with a tall and slim profile for standing on the floor against a wall with no rear access required to ensure a minimal floor area requirement. Aluminium feet with plastic pads on the underside are fitted as standard. There are also anchor points for bolting the battery to the wall where required eg. when installed into a container prior to transporting to site.

The Ah capacity is provided in the tables for each model for easy reference.

The maximum current for each model is governed by the rating of the built-in circuit breaker [3], which has been sized below the maximum current capability of the lithium cells. There is no noticeable temperature rise during operation and no cooling of the cells is required.

There is no specific time limit for operation at the maximum current, however, to ensure that the circuit breaker does not trip in normal operation, it is advised that the design of the system aims to remain at or below the continuous current value.

Figure 2.1 Labelled Image of the Freedom Lite Commercial 100/80 (Labelling corresponds with the text)

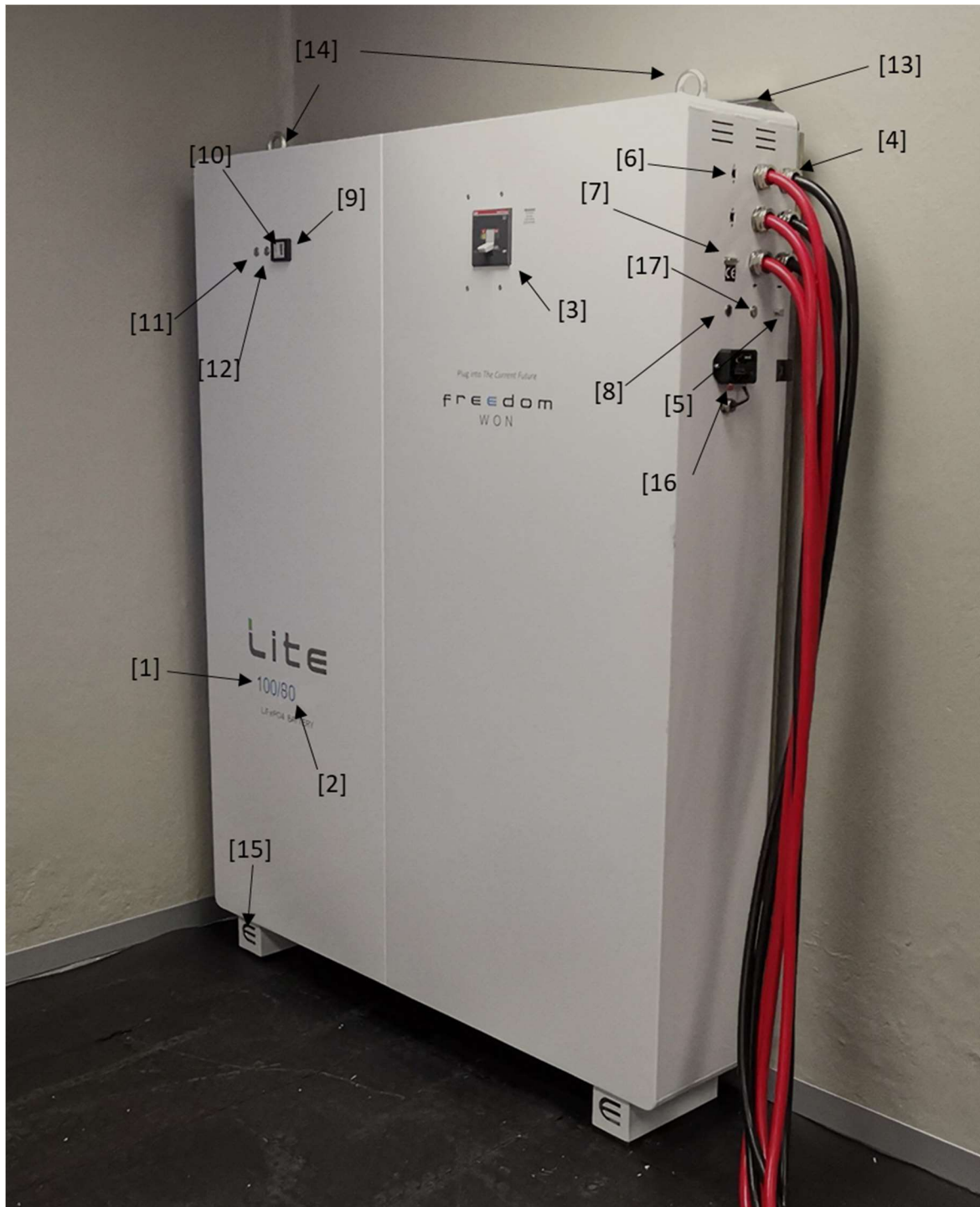

1. Gross Capacity
2. 80% Capacity maximum recommended for daily cycling (max available is 90%)
3. Breaker
4. Power Cables
5. DB15 Analogue and Relay Control Port (note this is not fitted on models made from January 2020 onwards)

6. *CAN Bus Sockets x 2 (RJ45) (one socket must contain a termination resistor if end of line)*
7. *DB9 Programming Port (not visible in photo)*
8. *Reset Button*
9. *State of Charge Display*
10. *Error Lite*
11. *On Button*
12. *Off Button*
13. *Safety Retaining Tabs*
14. *Lifting Eye Bolts*
15. *Feet*
16. *WiFi Connect Data Logging and Reporting*
17. *Override Button*

For the 52V models the absolute maximum allowable voltage when fully charged is 56V, however a more typical inverter setting range is 55.5V to 55.8V, depending on the inverter voltage tracking accuracy in preventing a voltage overshoot above 56V. The voltage normally used as the minimum cut off is 48V, however this will not typically be reached if operating down to 90% Depth of Discharge (DoD). The BMS will command the connected inverter with CAN Bus interface to stop discharging the battery at 10% SoC (90% DoD), which roughly equates to 49,0V). Under high load the voltage may drop to 48V whilst still above 10% SoC. A voltage of 48V or even lower can be observed where the standby current draw on the inverter has caused the battery to be discharged below 10% SoC or below the 48V minimum cut off voltage. The battery breaker will eventually trip the battery at around 47V to protect the cells from undervoltage.

The Commercial HV models typically operate at 512V as this is the ideal operating voltage for the ATESS HPS hybrid battery inverters (a common pairing). The HV+ models operate at 576V up to 717V depending on the model. This voltage range suits the ATESS PCS battery inverters and associated PBD DC Charge controllers.

The weight of each model is given in the tables 2.1 and 2.2. The Freedom Lite Commercial 100/70, 120/84 and 140/98 are assembled complete in the Freedom Won factory as standard. The 160/112 up to the largest 700/490 are either assembled on site by a Freedom Won site team or, if preferred by the client, can be built into a container at Freedom Won by the Freedom Won factory team.

The 100/70, 120/84 and 140/98 models require specific lifting equipment to place them into position. Should a specific site present logistical constraints in relation to placing these models into position, it is possible to request that Freedom Won assemble the batteries on site at an additional cost.

The dimensions given in the specification sheets are for the principle outlines of the battery housing and exclude items that protrude such as the DC cable glands and the circuit breaker handle.

The DC cables exit the unit through glands located near the **top of the right hand side** of the casing (as in Fig 2.1) for the 100/70 and 120/84 models, and **near the right side of the top** of the casing for the rest of the 52V range (as in Figure 2.2).

*Fig 2.2 Top Cable Exit Example on a Lite Commercial 200/140*



The DC cables per pole vary in number and size across these models [three in Figure 2.1 for example]. The correct cable lugs for connecting these leads to the inverter must be in hand when doing an installation. If there are several inverters and charge controllers that need to be connected to the battery it is advisable to install a DC connector box to use as a junction point from which to branch out to all the battery connected equipment. Note that the cables are provided 3m long as standard and up to 5m long can be ordered at extra cost.

Note that the HV and HV+ models have bottom exit cables that exit on the bottom right hand end of the battery as in Fig 2.3.

Fig 2.3 Installation Example of a Lite Commercial 100/70HV (now 100/80) with a ATESS HPS50 and no cable trench (trunking used instead)



Two RJ45 sockets [6] are provided, one for connecting the CAN interface from the battery to the system controller or directly to the inverter depending on the brand, and another for connecting the battery to another battery or for a termination resistor (more detail later in manual).

A DB9 Serial Connector [7] is fitted for use by technicians for programming the required profile onto the BMS. The required profile is typically loaded by Freedom Won prior to delivery or during commissioning for site build models but installers are advised to obtain the correct adapter to allow Freedom Won to program batteries remotely on behalf of the installer via the installer's Windows laptop if necessary. Note the correct adapter for the Lite Commercial range is a CANdapter (Figure 2.4). This is available from Freedom Won as an accessory; however all batteries are supplied with one CANdapter as standard.

An error reset button [8] is positioned near the DB9 plug for clearing BMS errors.

Freedom Lite is also fitted with a State of Charge (SoC) display [9], which includes a red LED error indicator [10] and below it a "low power" indicator.

The ON button [11] and OFF button [12] are located beside the SoC display.

The Lite is supplied with securing tabs along the top and bottom as part of the rear cover to secure the battery against the wall to prevent it from tipping over [13] or shifting if installed into a container to be transported to site.

All models are supplied with permanently installed eye bolts [14]. For the 100/70, 120/84, and 140/98, these eye bolts are provided for lifting the full battery mass. For the larger models (160/112 and larger) these eyebolts are provided for lifting the empty casing only (prior to battery assembly). Do not attempt to lift these models using the eye bolts after assembly is completed.

All Lite's have feet as standard, with plastic slippers underneath [15].

A WiFi Connect logging device is fitted as standard to all Lite Commercial models [16], which must be commissioned when the plant room WiFi is available by following the instructions in the manual at this link:

[https://www.orionbms.com/downloads/documents/connect\\_quickstart.pdf](https://www.orionbms.com/downloads/documents/connect_quickstart.pdf)

Table 2.1 Freedom Lite Commercial 52V Range Overview

Freedom Lite Commercial	100/80	120/96	140/112	160/128	200/160	300/240	400/320	500/400	600/480	700/560
Total Energy Capacity [kWh]	100	120	140	160	200	300	400	500	600	700
80% DoD Energy [kWh]	80	96	112	128	160	240	320	400	480	560
90% DoD Energy [kWh]	90	108	126	144	180	270	360	450	540	630
Current Capacity [Ah]	2 000	2 400	2 800	3 200	4 000	6 000	8 000	10 000	12 000	14 000
Max. Cont. Charge and Discharge Current (1) [A]	2 000	2 000	2 400	2 400	2 400	2 800	2 800	2 800	2 800	2 800
Max. Cont. Charge & Discharge Power (1) [kW]	100	100	120	120	120	140	140	140	140	140
Nominal Voltage (2) [V]	52									
Max. Inverter Cap. [kVA]	90	90	108	108	108	135	135	135	135	135
Total Weight [kg]	1 040	1 250	1 500	1 700	2 200	3 300	4 300	5 300	6 300	7 400
Height [mm]	2 100									
Depth (from wall) [mm]	350						750			
Length (width along wall) [mm]	1 400	1 850	2 300	2 750	3 200	4 600	3 300	4 300	4 700	5 600
DC Connection – Fly Leads, [no. per electrode] (3) [mm <sup>2</sup> ]	3x120	3x120	4x120	4x120	4x120	6x120	6x120	6x120	6x120	6x120
Round Trip Efficiency	96-97%									
Enclosure	3mm thick Aluminium, powder coated, tamper proof, indoor use									
External Interface	CAN Bus									
On-board Management	Comprehensive battery management system and internal trip protection									
Human Interfaces	On and Off Buttons, State of Charge Display (0 to 100%), Error light, Error Reset Button, CANdapter for Programming and data access with PC, main breaker									
Protection	Shunt Trip Circuit Breaker sized to suit max current, tripped by BMS if critical fault, manual reset. Protection for overcurrent, cell under and over voltage, temperature, weak cell detection and other critical events									
Battery Chemistry	Lithium Iron Phosphate (LiFePO <sub>4</sub> )									
Cell Form Factor	Large Format ultra-heavy-duty prismatic cells of 200Ah each and 3,2V nominal voltage, fully sealed in plastic casing with bolt on electrode connections									
Battery Cooling	Natural Convection (heat generation is negligible inside the battery)									
Suitable Ambient Temp [°C]	0°C to +40°C									
Extreme Operating Temp [°C] (4)	-20°C to +60°C									
Remote Monitoring	Real time data logging and transmission via WiFi to online portal of key battery information									
Warranty (5)	10 years or 4 000 cycles for average 80% DoD, and max 90% DoD									
Design Life – Cycles	>16 years (>5 500 cycles) expected life at 80% DoD per cycle, >20 years (>7 500 cycles) at 50% DoD									

Notes to Specification Sheet:

- The maximum (peak) and continuous current and power ratings are the same for the Lite Commercial battery range. The maximum values given apply to both charge and discharge. For systems requiring more than 140kW, two or more batteries must be installed in parallel.
- For higher battery voltages refer to the Freedom Lite Commercial HV and HV+ ranges.
- Fly Leads 3.0m long as standard, power cable Red = Positive, Black = Negative, conductors in table refer to one electrode i.e. per positive and negative connections. Up to 5m long available at extra cost (must be specified in order). Note that the fly leads exit the battery as follows according to the model:
  - Model 100/70 and 120/84 – Exit is on the right-hand side of the battery enclosure near the top
  - Other models – Exit is on the top of the battery near the right-hand side
- Charging below 0°C not permitted. Extended time above 45°C not recommended for optimal battery life.
- See Freedom Won Warranty document for further detail.

Table 2.2 Freedom Lite Commercial HV and HV+ Range Overview (to suit ATESS and similar inverters)

Freedom Lite Commercial ‡	100/80 HV	120/96 HV	140/112 HV+	160/128 HV	200/160 HV	230/184 HV+	300/240 HV (HV+)	400/320 HV (HV+)	500/400 HV (HV+)	600/480 HV (HV+)	700/560 HV (HV+)
Total Energy Capacity [kWh]	100	120	140	160	200	230	300	400	500	600	700
80% DoD Energy [kWh]	80	96	112	128	160	184	240	320	400	480	560
90% DoD Energy [kWh]	90	108	126	144	180	207	270	360	450	540	630
Current Capacity [Ah]	200	200	200	400	400	400	600 (400)	800 (600)	1 000 (800)	1 200 (1000)	1 400 (1000)
Max. Cont. Charge and Discharge Current (1) [A]	220	200	200	280	400	400	600 (400)	800 (600)	800	800	800
Max. Cont. Charge & Discharge Power (1) [kW]	112	120	143	115	200	230	300	400 (500)	400 (500)	400 (500)	400 (630)
Nominal Voltage (2) [V]	512	602	717	410	512	576	512 (768)	512 (682)	512 (640)	512 (614)	512 (717)
Max. Inverter Cap. [kVA]	120	120	140	120	200	230	300	400 (500)	400 (500)	400 (500)	400 (630)
Total Weight [kg]	1 040	1 250	1 500	1 700	2 200	2 500	3 300	4 300	5 300	6 300	7 400
Height [mm]	2 100										
Depth (from wall) [mm]	350							750			
Length (width along wall) [mm]	1 400	1 850	2 300	2 750	3 200	3 200	4 600	3 200	4 100	4 600	5 500
DC Cables, [no. per electrode] (3) [mm <sup>2</sup> ]	1x70	1x70	1x70	1x95	1x95	1x95	1x120	1x185	1x185	1x185	1x185
Round Trip Efficiency	96-97%										
Enclosure	3mm thick Aluminium, powder coated, tamper proof, indoor use										
External Interface	CAN Bus										
On-board Management	Full battery management system and internal trip protection										
Human Interfaces	On and Off Buttons, State of Charge Display (0 to 100%), Error light, Error Reset Button, CANdapter for Programming and data access with PC, main breaker										
Protection	Shunt Trip Circuit Breaker sized to suit max current, can be tripped by BMS if critical fault, manual reset. Protection for overcurrent, cell under and over voltage, temperature, weak cell detection and other critical events										
Battery Chemistry	Lithium Iron Phosphate (LiFePO <sub>4</sub> )										
Cell Form Factor	Large Format ultra-heavy-duty prismatic cells of 200Ah each and 3,2V nominal voltage, fully sealed in plastic casing with bolt on electrode connections										
Battery Cooling	Natural Convection (heat generation is negligible inside the battery)										
Suitable Ambient Temp [°C]	0°C to +40°C										
Extreme Operating Temp [°C] (4)	-20°C to +60°C										
Remote Monitoring	Real time data logging and transmission via WiFi to online portal of key battery information										
Warranty (5)	10 years or 4 000 cycles for average 80% DoD, and max 90% DoD										
Design Life – Cycles	>16 years (>5 500 cycles) expected life at 80% DoD per cycle, >20 years (>7 500 cycles) at 50% DoD										

## Notes to Specification Sheet:

‡ The Lite Commercial high voltage range is available in two variants, namely the HV and HV+. The HV models are suitable for the ATESS HPS range of hybrid battery inverters and the HV+ is suitable for the PCS range of battery inverters and associated PBD DC charge controllers. Note that integration with other inverter brands is feasible – please contact Freedom Won for assistance.

If either HV or HV+ is not shown in the table under the model name it means it is not available for the respective size battery. You will need to select the closest size option that is available.

### *Freedom Lite Commercial Installation Manual Revision 3*

1. The maximum (peak) and continuous current and power ratings are the same for the Lite Commercial HV and HV+ battery range. The maximum values given apply to both charge and discharge. For systems requiring more than 400kW from the Commercial HV range and 630kW for the HV+ range, two or more batteries must be installed in parallel.
2. Higher voltage custom batteries are available on request ranging up to 750V DC (nominal) should this be required for other types of inverters. Note that custom voltages may result in different battery capacities from what is included in this specification sheet – please contact Freedom Won for further details.
3. Fly Leads 3.0m long as standard, power cable Red = Positive, Black = Negative, conductors in table refer to one electrode i.e. per positive and negative connections. Up to 5m long available at extra cost (must be specified in order). Note that the fly leads exit the battery on the right-hand side near the floor on all the Lite Commercial HV and HV+ models. This is to suit the bottom entry of the floor standing ATESS inverters. A cable trench is recommended for routing this cable along with all the other cables going to and from the inverter (a cable tray is an alternative).
4. Charging below 0°C not permitted. Extended time above 45°C not recommended for optimal battery life.
5. See Freedom Won Warranty document for further detail.

*Figure 2.4 CANdapter for Programming Freedom Lite Commercial Range*



### 3. Transport, Handling, Final Positioning and Plant Room Design

The Freedom Lite units are packaged in protective foam layering and fastened into a wooden crate with feet, which allows lifting with a forklift or a pallet jack.

For the 100/70, 120/84 and 140/98 models the battery is transported complete in a single crate of outside dimensions 150mm longer, wider and higher than the respective battery dimensions provided in the specification sheet.

For the 160/112, 200/140 and 300/210 the battery casing is shipped as one piece in one crate, also with outside dimensions 150mm longer, wider and higher than the respective dimensions given in the specification sheet. These casings are however not populated with the lithium cells for shipping, which are shipped in separate crates of a size (587mm x 325mm x 350mm high) and weight (72kg) that can be lifted by two men if necessary. These crates can also easily be handled with a pallet trolley or forklift.

The 700/490 enclosure is shipped in two halves (each 2 750mm long) and the other models are shipped in one part (see specification sheet or Table 2.1 and Table 2.2 for dimensions).

For a complete packing list of each model please enquire with Freedom Won.

The models shipped to site complete may be lifted using the fitted eye bolts. The models shipped unassembled also have eye bolts fitted to the enclosure, which may be used only for lifting the EMPTY enclosure into position. These eye bolts MUST NOT be used for lifting the completely assembled battery.

Note that the door to the plant room must be sized adequately in width and height for entry of the casing. A minimum door opening of 2,3m high x 1,6m wide is recommended. A minimum roof or ceiling height of 2,4m is recommended to accommodate the top exit power cables and related cable tray design.

The floor of the plant room should be level power floated concrete, preferably painted with a floor epoxy or sealed with cement sealer.

Manoeuvring area inside the plant room must be adequate for positioning the casing through the door into the final position.

There must also be sufficient space around the battery to meet the assembly space requirements for the models that are assembled on site:

1. The models 160/112, 200/140 and 300/210 are assembled from the rear of the casing by removing the rear cover, fitting the cells, and replacing the cover. At least 700mm of clearance is required behind the battery for the assembly process. Once the rear cover has been fitted the battery is moved back against the wall using 2t pallet trolleys. One pallet trolley is sufficient for the 160/112. For the 200/140 and 300/210, two such trolleys are required. **Note:** the smaller models can also be positioned inside the plant room using one 2t pallet trolley.
2. The models 400/280 to 700/490 are assembled from the front and therefore the empty enclosure is first placed in its final position against the wall and then the cell

modules are fitted from the front. A minimum of 750mm space in front of the enclosure is ideal for installing the modules. However, in the case of two of these models being fitted into a shipping container the centre aisle space is limited to 500mm, which can be accommodated.

Fixing holes are provided at the top and bottom of the rear of the enclosures for fixing the batteries to a wall or container side to prevent movement after installation. These are specifically required when a battery is installed into a container that will be transported to site complete with battery and other equipment.

**Note:** All Lite Commercial models can be offered complete ex-factory installed into a shipping container. Such systems are pre-commissioned at the Freedom Won factory and can be combined with the required battery inverters supplied and fitted by Freedom Won.

For lifting the factory assembled Commercial units into position specialised equipment is required. A high-up crane truck or a forklift is required for offloading. For lifting the battery upright a crane or forklift can be used if there is sufficient height clearance, otherwise a mobile gantry crane like the one pictured below should be used. These cranes are available from Freedom Won in three sizes:

1. Small – for lifting models up to Lite 60/42 (not applicable for Commercial range)
2. Medium – for lifting models up to the Lite 100/70
3. Large – for lifting models up to the Lite 140/98

Fig 3.5 Site Assembled Gantry with Electric Winch



**Caution:**

1. Handle the Freedom Lite with great care when lifting and manoeuvring. It should remain either lying flat on its back, or vertically upright (it must not be placed upside down or on its front face).
2. If manoeuvring through a doorway too low for upright handling is unavoidable the battery can be positioned (whilst still inside the crate) on its long side. Special packaging inside the crate is required for this procedure so Freedom Won must be notified of this requirement prior to collection.
3. Take care not to knock any of the protruding items against obstacles during handling such as the DC cabling and plugs and the circuit breaker handle.

4. Take care not to scratch the Lite during handling. Packaging foam should be used to protect the paint when being handled on a trolley or pallet jack.
5. Always ensure that lifting equipment and slings are adequately rated for the lifting weight.
6. Wear personal protective equipment such as safety shoes and gloves while handling and mounting the Freedom Lite
7. Always ensure that you have enough people on hand to perform the operation safely, i.e. at least two persons to guide and stabilise and two persons to hoist or handle the pallet jack(s).

## 4. Connecting the Freedom Lite

### 4.1 Power Cables

The Freedom Lite is simple to connect to the battery inverter. First of all you will connect the positive and negative cables to the inverter terminals or DC busbar if applicable using the applicable lugs (not supplied).

***Danger: The Commercial HV and HV+ range operates at potentially lethal voltages and hence the battery cables and connections must be treated with the utmost of respect – prior to connecting the positive and negative cables to the inverter be sure to check that the main battery circuit breaker is switched off. This will ensure that there are no short circuits between the loose ends of the cables and will also avoid electric shock from the battery during installation.***

The cables are supplied with the Freedom Lite, permanently fixed into the unit and secured onto the casing using compression cable glands. Attach crimp plugs to the ends of the cables ensuring that the correct terminal size is used, and the lug is matched to the size of the cable. The positive cable is red, and the negative cable is black. This is confirmed by + and – signs on the battery casing beside the respective cables. See Tables 2.1 and 2.2 respectively for the cable size and quantity fitted to each Freedom Lite model. The standard cable length is based on the inverter standing on the floor or mounted on the wall as applicable adjacent to the Freedom Lite battery so that the cable run is less than 3m (note that the standard cable length is 3.0m, longer cables available on request up to 5m). Note the inverter should always be on the right-hand side of the battery or opposite the battery with overhead cable routing.

Longer runs should be assessed, and larger cables or busbars considered, for extending the Freedom Lite DC connection with the objective of minimising voltage variation between the battery and the other DC connected equipment. Double insulation welding cable is recommended. In some instances, multiple cable lengths are used instead of using larger cable to ensure easier routing and bending of cables in trunking.

The cables may be routed through trunking (or on cable tray) and connected into the inverter on the positive and negative terminals respectively. The inverter terminals on most

inverters can then be used for linking up the charge controller(s) to the DC Bus. On Installations where there are too many inverters and/or charge controllers to connect to the DC bus using the inverter terminals as a junction point, a DC connector box or enclosed busbar is required. Where multiple cables per pole are fitted, the cables can be separately routed directly to separate equipment (inverters and charge controllers) – if this is done the installer must take care to ensure that any one of the cable pairs will not be overloaded. The cables for each pole are connected together inside the battery.

## 4.2 Control Interface

For controlling external devices, you will need to connect the CAN Bus control wiring that allows the Battery Management System inside the Freedom Lite to control and interface with these devices.

The CAN Bus connection uses a CAT5e or CAT6 ethernet cable plugged into an RJ45 plug on the battery.

CAN is a widely used communication protocol in systems with many devices that must report their status or send commands to other devices on the same network. The Freedom Lite BMS can transmit messages and commands in CAN protocol to provide information to, but more importantly to control, external devices. There are only two wires required in this form of communication, namely CAN High and CAN Low. In order for an inverter or charge controller to be controlled by CAN it must first of all be equipped with a CAN interface as well as a suitable method of connecting the CAN wires. Further to this the Freedom Lite BMS must be programmed with a CAN messaging profile that is developed for the inverter or charge controller being used. This profile must be specifically developed for each inverter model or model range.

The CAN Bus connection is made using the RJ45 plug with the pin configuration on the battery plug end provided in Table 4.1.

*Table 4.1 Colour Coding and Pin Configuration for CAN Bus Control Cable*

RJ45 Pin No.	Standard Ethernet Cable Colours	Wire Function
Pin 7	Brown/White	CAN High
Pin 8	Brown	CAN Low

There is no ground pin provided on the battery for the CAN Bus.

For Victron systems using the Color Control or Venus the pin configuration is straight through and therefore a standard ethernet cable can be used. For other inverters such as SMA this configuration is such that a special cable is required – please refer to the respective inverter brands manuals for their pin configuration or contact Freedom Won for assistance. Special cables for all the supported inverter brands are available from Freedom Won (see accessories section). Some inverters have free terminal connections that therefore do not require a plug on the inverter end of the CAN Bus cable eg. ATESS.

If a particular inverter under consideration only has a Modbus control input for the BMS we recommend as first option considering another inverter that has a CAN Bus input. If this is not practical, please discuss the project with Freedom Won so that we can consider using a CAN Bus to MODBUS converter.

To date Freedom Won has developed CAN profiles for the following equipment:

- SMA Sunny Island Battery Inverters
- Ingeteam Sun Storage Battery Inverters
- Victron Multiplus and Quattro Battery Inverters and MPPT Controllers via the Color Control GX and Venus system controllers
- Studer
- Imeon
- Solax
- Goodwe
- MLT Drives (2019 models onwards)
- Socomec
- Koyoe
- ATESS (HPS and PCS ranges)
- Sunsynk

Freedom Won welcomes any requests to produce BMS CAN profiles for other inverters that are CAN equipped for BMS interface.

The CAN interface can provide the following functionality to compatible devices:

- i. Charge Current Limit of all Lite's connected
- ii. Discharge Current Limit of all Lite's connected
- iii. Actual State of Charge (minimum of all lights connected)
- iv. Actual Battery Temperature (highest of all lights connected)
- v. Actual Voltage
- vi. Actual Current (total of all Lite's connected)
- vii. Maximum real time charge voltage setpoint
- viii. Battery Name
- ix. Highest Cell Voltage of all Lite's connected
- x. Lowest Cell Voltage of all Lite's connected.
- xi. Firmware Version
- xii. Ah capacity of all batteries connected
- xiii. Advanced communication between all connected Lites

The CAN 2.0 Part A and Part B standard uses the SAE J1939 standard in the Lite. It is necessary to install a 120 Ohm resistor on each extreme end of the CAN cable. Most devices operating on CAN have two plugs to connect in and then out again on the common CAN Bus. The first and the last device in the chain must have a termination resistor plugged into the spare (second) plug. These resistor plugs are available from the inverter manufacturer and

from Freedom Won. SMA, Imeon, Solax and Victron operate on this basis. ATESS for example has a separate CAN terminal block for bare wires to be inserted from the BMS and these units have an internal resistor fitted into the device. All Freedom Lite models have two CAN plugs for parallel configurations (Figure 4.2) and allow fitment of the termination resistors on the end of line units. Where one Lite is installed or where it is the end of line CAN device, **the Lite must be fitted with a termination resistor by plugging a RJ45 resistor into the second RJ45 socket on the battery.**

The resistor fitted to the battery must be the item manufactured by Victron, also available from Freedom Won. The termination resistor provided by other inverter brands such as SMA will not work for the battery end termination, only for the inverter end. **These resistors are not supplied as standard with the battery and should be included in the order with Freedom Won.**

For Victron systems the Victron Color Control or Venus is supplied with 2 x termination resistors. For parallel Lite configurations installed on inverter systems where these resistors are not supplied, it is necessary to purchase two from Freedom Won.

The third-party device manuals must be referenced for all details regarding connecting the CAN interface.

Most brands use 500kbps. If 250kbps is required it is available on the Lite with a specific profile loaded and should be requested in the order. This can however be changed at any stage by updating the profile using a PC.

If you did not purchase a CAN Bus cable to suit your inverter you can make your own according to Table 4.2. Fig 4.1 provides the standard colour coding for an Ethernet cable (note that there are other variations so double check this).

Fig 4.1 Pin Configuration for standard RJ45 plug



Table 4.2 Pin Configuration for CAN Bus Control Cable for various supported inverters

Wire Function	Standard Lite and Victron	SMA Sunny Island	Ingeteam, ATESS	Imeon	Solax	Goodwe	Sofar

CAN Low	Pin 8 (brown)	Pin 5 (blue/white)	Labelled on inverter	Pin 2 (orange)	Pin 1 (orange/white)	Pin 5 (blue/white)	Pin 2 (orange)
CAN High	Pin 7 (brown/white)	Pin 4 (blue)		Pin 1 (orange/white)	Pin 2 (orange)	Pin 4 (blue)	Pin 1 (orange/white)
		<b>Bridge Pin 3 and Pin 6 on Inverter end or cable with a 120Ω resistor</b>					

If your inverter is not included in this table, please contact Freedom Won for assistance.

### 4.3 Parallel Configurations

It is permissible to connect multiple Freedom Lite’s in parallel provided that the Freedom Lite model size used is the same throughout. It is however more cost effective to purchase one larger Freedom Lite model than connecting multiple units in parallel. This type of installation should be reserved for future expansion where it is not feasible to purchase a model large enough upfront for future requirements (financial constraints).

One Lite is programmed as the Master, while the rest of the Lite’s connected to the DC bus are programmed as Slaves. A total of 10 units can be connected in parallel.

For installations using hard wired control to control the inverter or charge controller, the NO and COM dry contact pairs from external relays controlled by the Master Lite via the DB15 plug are used (see further in manual for more information on the dry contact pairs).

The Master Lite must be connected to the slave Lite’s via the CAN Bus using standard LAN cable.

Where CAN Bus is used to control the inverter(s) and charge controller(s), the CAN Bus from any battery (preferably the Master) can be connected to the inverter directly or the system controller, depending on the product brand. **All Freedom Lite Commercial models are shipped with hardware that enables them to be configured either as a master or as a slave.** This is achieved by providing two RJ45 sockets on the battery – refer to Figure 4.2. On the master, one socket is used for an end of line (termination) resistor, and the other socket for connecting to the next item of equipment, whether it be a slave battery, an inverter, a solar charge controller, or system controller. On a slave, each socket is used to connect to another item of equipment.

Figure 4.2 Picture Showing 2 x RJ45 Sockets for CAN Bus (DB15 Plug shown here for Analogue and Relay Control is not available in new models)

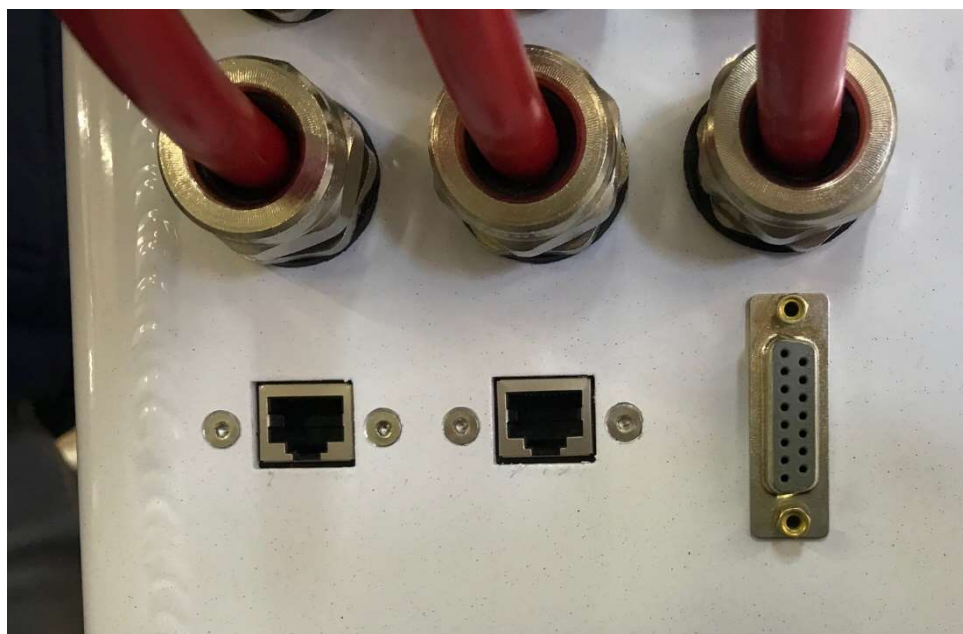
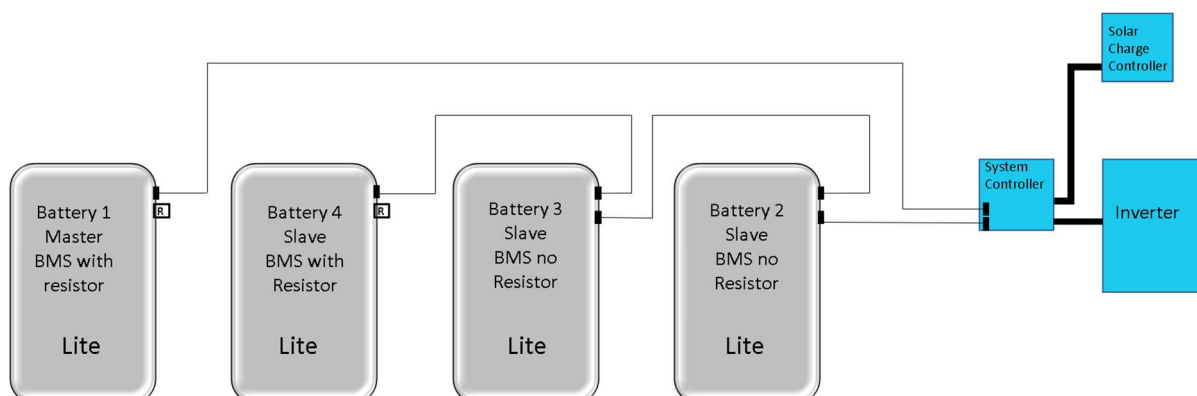

Figure 4.2 CAN Bus Connection Example with Four Lites



Freedom Lite batteries can configure themselves automatically for master and slave configurations with up to 20 slaves. No programming is required, simply connect the CAN Bus cables and switch on the Lite's. The Master will be the first battery that was switched on.

If the master Lite trips one of the slaves will take over as the master automatically without any interruption of service.

Freedom Won offers a fair trade in on Freedom Lite's on the purchase of new units, which is an option for somebody wishing to expand their battery capacity instead of installing parallel units. Please request more detail from Freedom Won if this is your upgrade preference.

New units can be placed in parallel with old units up to about 5 years or 1 500 cycles, after which it is preferable to trade in for a new larger unit.

New units can be placed in parallel with old units up to about 4 years or 1 300 cycles, after which it is preferable to trade in for a new larger unit.

## 1. Switching on the Lite

The Lite is fitted with an “ON” button. Press this button to switch on the BMS inside the battery. Once the BMS has been energised you will observe the SoC display come to life with the SoC level. Confirm at this stage that the error lite is not illuminated. If it is, contact Freedom Won. If the Reduced Power light is illuminated, do not be concerned, it should extinguish after the battery has been in operation for a few hours.

Once the BMS has been energised, the main breaker may be switched on by pushing the breaker upwards. Ensure beforehand that you have secured the DC cables to their proper locations and that the rest of the system is ready to receive battery voltage.

Note: On some inverters there is a large inrush current when switching on the DC supply. This may trip the battery breaker. Should this occur it is necessary to immediately push down the breaker handle to reset it, and then immediately attempt a second switch on. If the breaker trips again it is likely because of an error on the BMS and Freedom Won should be contacted to assist with diagnosing and clearing the error.

To switch off the DC output from the Lite, pull down the breaker. To switch off the power to the BMS, press the “OFF” button situated to the right of the “ON” button. This will also trip the breaker if it is still on at the time. The Lite must be switched off fully when not in use to prevent self-discharge.

Fig 5.1 "ON" and "OFF" Buttons



## 2. Programming the Freedom Lite

The DB9 connector on the left-hand side of the Freedom Lite is used for setting up the profile of the BMS. A CANdapter to USB adaptor is required for connecting Freedom Lite to a Windows personal computer. The computer must have the correct utility software installed. Programming of the BMS is a function performed by Freedom Won and approved representatives. Write access to the BMS profile is password protected, however users and owners may request read only access.

Freedom Won can program the Lite remotely using Teamviewer connected to a local PC connected as explained above.

## 3. Settings Required for Setting up Inverters and Charge Controllers for 52V systems (Freedom Won will assist with HV systems)

The maximum and continuous discharge currents for the respective models are provided in Table 2.1. and 2.2 respectively. For charge current settings the same limit can be used as the continuous discharge current, however this is usually not possible owing to limitations of the charger or of the incoming grid supply. An average recommended charge current is one third of the continuous rating of the battery. This will usually ensure that the combination of the mains charger and the Solar Charge Controller (SCC) does not exceed the maximum continuous charge current, although this must be specifically checked.

The voltage settings for the Freedom Lite range of nominally 52V batteries when operating in a system where the BMS can control the external devices as explained above are as follows:

- Minimum (cut off) – 47V (the Lite should never reach this low voltage but is it good to have this set as a redundancy protection measure.
- Low Battery Voltage Warning (if applicable, often used to revert back to grid power in increased self-consumption applications because it approximates 30% SoC) – 51V
- Max Charge Voltage – 55,8V (Bulk, Absorption and Float are all set to this value)

**If the BMS is not able to control the external devices** via CAN Bus then the voltages must be set at slightly conservative values. This is to reduce the likelihood that an outlying cell will reach its voltage limit ahead of the pack, which the external devices would not be aware of because they can only monitor the total pack voltage. Using a lower pack voltage to monitor and control charging and a higher voltage for discharge will allow a greater spread in cell voltage values without any of them reaching their limits. The BMS inside the Freedom Lite will deal with an excessive spread of cell voltages by balancing them out using the cell tap wires attached to each cell and its internal circuitry. If a cell voltage does reach its limit the BMS will be forced to intervene. This would be either by:

- switching off a contactor on the AC in, AC out, or PV DC input as mentioned earlier in this manual,
- or if the relevant one of these functions does not exist in a particular system,
- the BMS shutting down the main breaker on the battery

Frequent occurrences of these two situations is not desirable so the voltages should be set to the following to reduce this occurrence to abnormal circumstances:

- Minimum (cut off) – 49V
- Low Battery Voltage Warning (if applicable) – 51V
- Max Charge Voltage – 55.5V

A voltage can also be set according to user requirements on the inverter depending on how much battery power may be used before grid power will take over from the battery (if it is available). It should be determined based on how much battery SoC is desired at all times as a minimum to ensure adequate capacity to handle a grid outage or load shedding. The daily cycling depth is also a consideration for the user in terms of battery service life.

The recommended voltage for forcing the inverter back to grid power in a self-consumption setup is:

- 52,0V for approximately 60% DoD
- 51,0V for approximately 70% DoD

In non-CAN Bus systems fitted with DC solar charge controllers (SCC) the AC charger should stop charging at 53.5V to allow the remainder of the charge to be performed by the SCC.

The SCC voltage set point would be set to 55,8V if BMS control is functional and 55,5V without BMS control. Note that it may be necessary to use a slightly lower voltage initially if the cells have not had sufficient balancing time – if the battery trips prior to reaching 55,5V it is because one cell has reached its maximum too early. Try starting with 54,5V and then after several days of balancing increasing it to 55,5V. For Victron systems the Lite controls this voltage maximum automatically.

*Note: For applications where voltages are measured during high current discharge it might be necessary to adjust slightly the values given above to cater for cell internal resistance.*

*Note: For systems with an interface between the battery and the rest of the system it is advisable to use SoC for controlling charge and discharge algorithms as this is the only accurate method – using voltage as described above is only an approximation.*

#### 4. Restarting the Lite after a Low Voltage Trip

If the battery has been allowed to discharge to the critical low cut out voltage the battery will trip the circuit breaker and switch itself off internally. This situation will only occur in the event of a malfunction of the charging system such as a generator that failed to start at the required time. In systems without a generator it is possible for the battery to be drawn critically low if the solar charging system does not function correctly.

To restart the battery follow the following steps:

1. Switch off the AC output breaker in the inverter(s) to isolate the loads
2. Ensure that there is either AC grid/generator power active on the AC input of the inverter(s) or if this is not available ensure the solar charge controllers are active.  
Note: For systems with only PV inverters and no generator this exercise becomes more involved – further discussion on this scenario below.
3. Press and hold the battery “Override” (OVRD) and “On” buttons at the same time.  
Note: the “Override” button prevents the breaker from tripping and hence must never be pressed for more than is absolutely necessary to get the system to begin charging.
4. Switch on the circuit breaker
5. Observe whether current begins to flow into the battery by referencing the system controller interface. There may be a delay of up to 20 seconds before the charge current begins to flow. Ensure that during this delay period the discharge current is only what is required to satisfy the inverter standby power.
6. Once a charge current is observed ensure that the Lite error lite is not illuminated, if it is press the “Reset” button to extinguish it.
7. Then wait until the pack voltage is above 50V before releasing the “Override” and “On” buttons.
8. If the breaker trips and the battery switches off, try pressing the On button for 3 seconds. If the battery still switches off, try steps 2-7 once more.
9. If the battery still refuses to stay on please contact Freedom Won for assistance.

If only PV inverters are installed and there is no AC input available for the inverters it will be necessary to get the inverters to wake up from their standby mode that they have been put into by the battery. For some inverters this can be achieved by unplugging the CAN Bus cable on the battery. If this does not work it will be necessary to connect a PC to the battery to re-enable the inverters to get them to use the PV inverters to charge the battery – please contact Freedom Won.

## 10. Accessories

Freedom Won offers the following accessories:

Table 7.1 List of Accessories

Item	Description
120 Ohm Termination Resistor – RJ45	For plugging into the second CAN port for an end of line Battery (usually these are supplied with CAN Enabled inverters and hence it is generally not necessary to purchase from Freedom Won.
CANdapter	This is required for programming the Lite 80/56 model and larger via the DB9 plug.
Gantry	Available in one size option in relation to the Commercial range – that can lift upright models up to the 140/112. Fitted with 3 500kg electric winch, includes lithium battery and built in charger. Can be disassembled and reassembled in minutes for easy transportation.

## 11. Warranty and Repair

The Freedom Lite is sealed with a tamper proof warranty seal. It may not be opened by anyone other than Freedom Won and installers or repairers that have been explicitly approved by Freedom Won. The warranty on the unit will be void if the seal is damaged or missing.

If the Freedom Lite indicates an internal problem please contact Freedom Won or the installer that installed the system. Freedom Won will arrange that it is inspected and repaired.

The warranty will not cover damage to the control wiring resulting from draw of excessive current or any damage resulting from lightning. Damage caused by physical means to the battery housing, external and internal fittings, such as impact with other objects, or being dropped, is not covered by the warranty.

The standard warranty period is 10 years or 4 000 cycles at an average of 80% DoD, whichever should first occur. The battery is guaranteed to provide at least 70% of its new capacity at the end of this period or cycle number. The BMS records the number of cycles used. If you suspect that your Freedom Lite is delivering substantially below its minimum performance, please contact Freedom Won for an investigation. We will request that you fully charge the battery and switch on a defined load and measure the operating time in order for us to estimate the amount of energy produced until the battery has reached 70% DoD. If the unit is found to be underperforming it will be serviced such that the minimum performance guarantee is again restored. Freedom Won may arrange for an on-site service.

For more detailed warranty information please contact Freedom Won.

## 12. Expected Product Life

Freedom Lite is designed for optimal life cycle cost, which is a fraction of any other battery technology available on the market, in particular from 25% to 35% of the lifecycle cost of the range of lead acid and associated variants on the market. Please contact Freedom Won if you would like more detailed information for comparison with lead acid batteries than what is available on our web site.

Freedom Lite is expected to operate for 16 to 20 years (more than 5 500 cycles) in a daily cycling scenario with an average of 80% DoD per cycle. For applications with occasional cycling, such as for emergency backup, the service life expected is 20 years or more.

For applications where the cost per kWh delivered by the battery during its lifetime is of prime importance (i.e. maximum return on investment) we recommend that the battery be sized for an average cycle discharge of 50-60% DoD. In a daily cycling scenario such as for optimal solar self-consumption and off grid systems the expected service life is then 20 years or more than 7000 cycles. The defined end of life in this instance occurs when the battery capacity falls to 60% of the new capacity.

## 13. Troubleshooting Guide

Most issues with the Freedom Lite can be resolved using the guide below. If a problem cannot be resolved after referencing this table please contact Freedom Won or your approved Freedom Won supplier.

*Table 13.1 Troubleshooting Guide (applicable to units with On and OFF buttons)*

No	Problem Description	Cause/Solution
1	The Freedom Lite has no voltage on the main output cables	Check that you have switched on the main breaker switch. Note – only turn this on once you are satisfied that you have completed the installation and that there are no DC or control wires that can short out or touch ground or other wires. Also ensure that you are ready to accept AC voltage onto the inverter output before switching this breaker on. Also confirm that you have energised the BMS first by pressing the “ON” button for 3 seconds and as evidenced by the lights illuminated on the SoC display.
2	The BMS (indicated by battery SoC display lighting up) does not stay on after the ON button is pressed	First switch off the AC output breaker to ensure that the inverter cannot supply loads from the battery, then review the following: <ol style="list-style-type: none"> <li>1. Error light shows on the BMS – Check whether the red error light is illuminated on the SOC display when the ON button is held in. You can try to reset the error by pressing the RESET button for about 2 seconds while you hold the On button in. This should clear the error and</li> </ol>

		<p>allow the BMS to stay on after releasing the ON button.</p> <ol style="list-style-type: none"> <li>2. Battery has been discharged to critically low level – remove all potential loads from the battery and switch off the inverter(s). Then try to switch on the BMS. If it does not stay on follow the steps in Section 4 of this manual.</li> <li>3. Battery has been charged to critically high voltage level – usually leaving the battery for an hour will allow the cell levels to drop down within acceptable levels and allow the BMS to be switched on again.</li> <li>4. Ensure that the Emergency Stop button is released if fitted</li> <li>5. If the BMS still does not switch on please contact Freedom Won or Authorised Distributor</li> </ol>
3	<p>The main breaker switch keeps tripping each time I attempt to switch it on</p>	<p>There are several potential causes:</p> <ol style="list-style-type: none"> <li>1. The Battery Management System has not been switched on. The ON button must be pressed for 3 seconds. On release the SoC Display must remain illuminated.</li> <li>2. High inrush current on certain inverters – First preference is to pre charge the DC bus by switching on the solar charge controllers if present and in daytime. If this is not possible switch on the AC feed into the inverter and switch on the inverter. Some inverter makes will then pre charge the DC bus. If this is also not possible (off grid with no generator), try to close the breaker twice in quick succession – the second attempt must be within a second, before the inverter capacitors discharge again. This reduces the inrush current on the second closing attempt. If this does not work after the second attempt investigate the other options.</li> <li>3. Short circuit on the DC Bus or faulty inverter or MPPT causing high currents</li> <li>4. In a system with multiple Lites in parallel the reason could be that the battery you are trying to switch on is at a different voltage to the others – the voltages must be similar (within 2V of each other) on all batteries when switching them onto a common DC bus.</li> </ol> <p>If none of the above solves the problem you will need to contact Freedom Won or your authorised installer for assistance with this issue.</p> <p>It will be necessary to establish the reason for the error before continuing with normal operation of the system.</p>

		Repeated unnecessary tripping is damaging for the breaker.
4	I have switched off the main battery breaker switch to prevent discharge of the battery but the SOC display lights are still on.	The BMS and SoC display receive power directly from the battery and therefore the "OFF" Button must be pressed to switch off the internal electronics.
5	The inverter will not come on even though the inverter switch is selected to 'on'.	The enable command may not be coming from the BMS or may not be properly connected to the inverter or the inverter may not be properly configured to deal with the enable command. If you are running on a CAN Bus control with a compatible inverter and you are not observing the correct enable response from the inverter check that the CAN High and CAN Low wires are connected properly (ensure that you have the High and Low the right way around and that you have connected the two end of line 120 Ohm resistors in the applicable places. If this is not the problem then you need to confirm that you have the right CAN profile programmed onto the BMS for the inverter in use (baud rate or CAN messages may be for another inverter brand) or that you have configured the inverter or system controller correctly. Contact Freedom Won or your Authorised Distributor for assistance
6	The charger will not come on even though there is power on the AC input of the inverter and the charger is activated in the inverter settings	The battery might be full. Try discharging the battery for a while and observe if the charger then comes on. If not then the fault finding process is similar to above.
7	The Freedom Lite error light keeps illuminating after each reset	If the battery voltage is within limits this should not ordinarily occur. Contact Freedom Won or an approved installer for assistance with determining the problem. If the main breaker does not trip it is not a critical error and you may continue using the battery while you make contact for assistance.
8	The pack voltage is within limits but the main breaker still trips seemingly at random	This could be caused by many things but is most likely because the current draw is exceeding the battery current limit setting. Measure the current with a tong tester while drawing your maximum typical load to determine if you are exceeding the rated current for the respective Freedom Lite model. If it is not the current causing the trip it could be a weak cell, faulty breaker, or extreme temperature of the surroundings. All are unlikely but can happen. If the problem persists contact Freedom Won.