



# Installation and User Manual Freedom Won Standard EMS Installation Manual

Manufactured By Freedom Won (Pty) Ltd

Hereford Rd

Longmeadow Business Estate

Modderfontein, Edenvale

1609

South Africa



[www.freedomwon.co.za](http://www.freedomwon.co.za)

## Technical and Installation Assistance – Contact:

Please contact your Freedom Won Distributor or Reseller Installer for technical and installation support. A directory of Distributors and Reseller Installers is available at

[www.freedomwon.co.za](http://www.freedomwon.co.za).

For advanced support please contact [support@freedomwon.co.za](mailto:support@freedomwon.co.za).

## Update Record:

Revision Number	Update Summary	Updated By	Date of Issue
0	First Release of the Standard EMS Installation Manual	Mike Marquis Jarod Lesser	15/08/2024
1	Added Mains terminals, dimensions of the panel, minor spelling errors	Technical Training Team	12/09/2024
2	Included requirement to provide auxiliary power to the gen and load meters.	Technical Training Team	22/10/2024

## Table of Contents

1.	Introduction .....	2
1.1	Purpose of the User Manual .....	2
1.2	System Requirements .....	2
1.3	Contents of the EMS Package .....	2
2.	Installation .....	3
2.1	Prerequisites .....	3
2.1.1	Basic EMS installation.....	3
2.1.2	Controllers and Monitoring Requirements.....	3
2.2	EMS Panel Dimensions.....	5
2.3	Terminal Layouts .....	5
2.4	Installation Steps.....	7
2.4.1	Site Inspection .....	7
2.4.2	Mounting the EMS Panel.....	7
2.4.3	Connecting Power to the EMS Panel .....	8
2.4.4	Connecting Communication Cables .....	9
2.4.5	Configuring 3 <sup>rd</sup> party controllers .....	10
2.4.6	Connecting the Internet to the EMS Panel.....	11
2.4.7	Connecting the GSM Antenna .....	12
2.4.8	Connecting the backup batteries.....	12
3.	Getting Started .....	13
3.1	Power ON .....	13
3.2	Lights on the EMS Panel.....	13
3.3	Commissioning of Devices .....	13
4.	Troubleshooting.....	14
4.1	Power switch not working. ....	14
4.2	Error light staying illuminated. ....	14
4.3	Not getting communication to a controller on the site.....	14
5.	Upgrades.....	15
6.	Maintenance.....	15
6.1	Help and Support.....	16

## 1. Introduction

### 1.1 Purpose of the User Manual

This manual is intended to assist trained technicians and installers in installing and commissioning a Freedom Won EMS (Energy Management System). It is not intended to teach the inner workings of a Freedom Won EMS; its function is to assist the installer in completing a successful installation and integration with other equipment.

The manual will not cover the technical details required for the integration of third-party equipment. Should this document not cover the required integration or technical details, please contact Freedom Won at support@freedomwon.co.za

### 1.2 System Requirements

The computer-based requirements for the system to be installed and function are as follows:

Compatible web browser: Microsoft Edge, Google Chrome, Firefox, Opera, Safari

Mobile devices will need an Android or MacOS.

In order to setup the software portion of the EMS system one will have to have access to the internet, setup a valid account on the EMS Portal and have the relevant permissions on that account to add and configure the hardware installed on site.

### 1.3 Contents of the EMS Package

The following items are included with your EMS purchase:

TABLE 1: PACKAGED CONTENTS

Item	Qty	Packaged	Received
EMS Panel 650x400x200mm	1		
Wall Mount Brackets	4		
GSM Antenna, 3m cable, SMA	1		
Freedom Won 12v/7.5Ah LiFePo4 Battery	1		
Installation Manual	1		
Termination Resistors	5		

## 2. Installation

### 2.1 Prerequisites

The correct tools and materials should be utilised to install the EMS Panel effectively and achieve a reliable and consistent outcome.

These prerequisites will serve as a guide for the items required alongside the EMS offering to correctly install the system.

#### 2.1.1 Basic EMS installation

The following list will assist in having the right hardware to do a reliable installation.

1. EMS Panel
2. 6A Circuit Breaker
3. PG9 and PG11 Glands
4. 40x25mm Trunking
5. 1mm<sup>2</sup> flat Twin and Earth
6. 8mm Fischer plugs and screws or appropriate Rawl bolts
7. Belden Shielded twisted pair 0.22mm<sup>2</sup> or Belden Shielded twisted pair 0.5mm<sup>2</sup>
8. Cat5 With Shield or CAT6 LAN cable
9. RJ45 Connectors
10. RJ45 Cable Rubber
11. Phone, Laptop or Tablet with the appropriate web browser
12. Stable Site internet connection

#### 2.1.2 Controllers and Monitoring Requirements

The EMS panel can be connected to a wide variety of 3<sup>rd</sup> party supported hardware, or controllers. These controllers must be wired with the appropriate supported communications. The EMS System supports **Modbus RS-485** and **Modbus TCP** connections and communication protocols to the EMS Panel. The Panel has several physical connection inputs on the side of the panel to plug in the various controllers.

This hardware includes connection to:

- Power Meter
- Power analysers
- Solar Grid Tie Inverters
- DC Coupled Solar Systems.
- Freedom Won BESS
- Generators

For a full list of the exact support hardware for the EMS system, please click [here](#).

For optimal function of your EMS system, install Electricity Meters or Power Analysers at each connection point through the power generation system. This will ensure that consistent, reliable data is fed to the EMS, which then processes the data and provides the best control to the system possible.

The mains and generator power meters used on the EMS site must have auxiliary power provided by the hybrid inverter's output. If this cannot be done, another form of backup power

must be provided to the power meters. This ensures that the power meters stay on when there is a loss of power or loadshedding.

As soon as multiple power providers are being summed into the same input it is advisable to put a power meter down at that summation point to give the most accurate readings possible.

The rule of thumb is that a measured value will always be more accurate than a calculated one. Use electricity meters or power analysers to provide this measurement rather than attempting to summate multiple power producers or consumers.

As an example, let's look at the singleline diagram below of a basic site with 2 generators and 2 grid tie solar systems. Take note of all the locations marked in blue as these would be sites where one would install additional power meters to get the most accurate and reliable data rather than adding up the data from each separate system.

It is vital that the appropriate cables are run between the various meters and the EMS panel, improper wire and communication wiring practices here will render the system unreliable and inconsistent.

Figure 1: Electricity meter layout

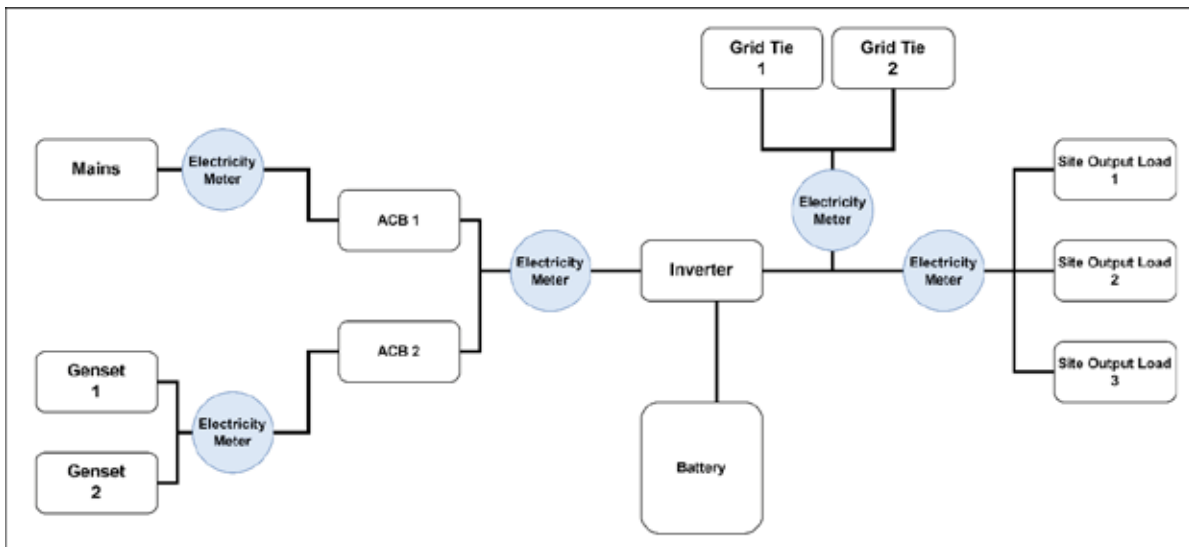

## 2.2 EMS Panel Dimensions

The following panel dimensions are subject to change based on the panel version as the panels are continuously being developed and improved.

Figure 2: Panel dimensions

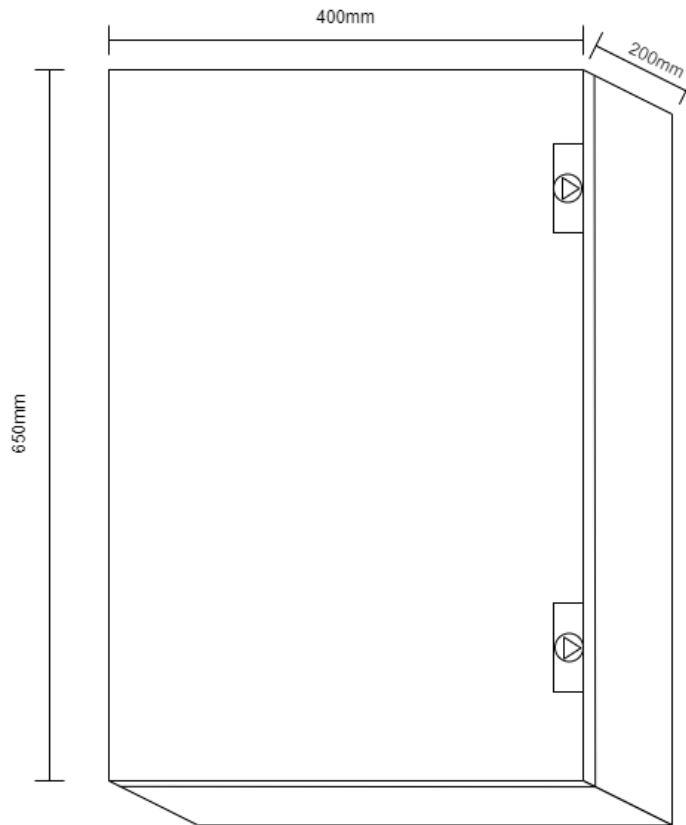

## 2.3 Terminal Layouts

There are terminals inside the panel to connect your digital inputs, digital outputs, and RS-485 connections.

### 2.3.1 Internal Terminals

The terminals are for wiring in Digital Inputs, Digital Outputs and RS-485 connections. Table 2 below highlights the various terminal numbers and their denominations in the EMS Panel.

TABLE 2: TERMINAL LAYOUT

Terminal Number	Digital Inputs	Terminal Number	Digital Outputs	Terminal Number	RS-485
4	GND	10	<b>DO 2</b>	16	A+
5	<b>DI 2</b>	11	GND	17	B-
6	GND	12	<b>DO 3</b>	18	GND
7	<b>DI 3</b>	13	GND	19	A+
8	GND	14	<b>DO 4</b>	20	B-
9	<b>DI 4</b>	15	GND	21	GND

E	N	L
Earth	Neutral	Live

Figure 3: Terminal layout

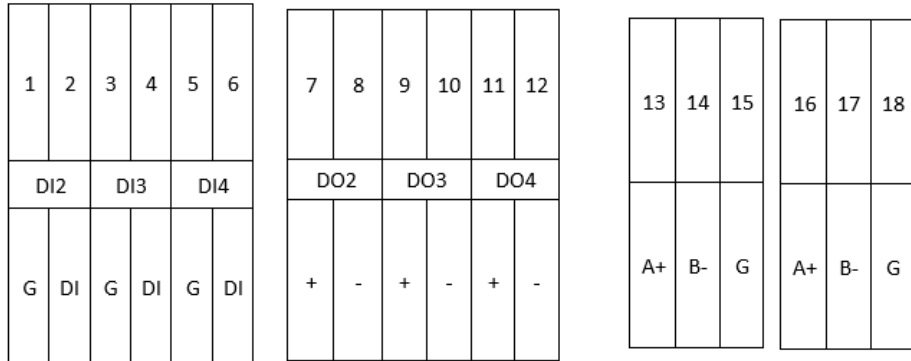

### 2.3.1.1 Power Input

The system requires 230V AC power. There are three connections for the power: Earth, Neutral and Live

### 2.3.1.2 Digital Inputs

The digital inputs can be found in the 2<sup>nd</sup> bank of terminals from the left-hand side in the panel. There are three inputs in total. The odd pins (1,3,5) are wired directly to the PLC and the even terminals (2,4,6 etc.) are connected to ground. When the appropriate odd and even terminals are connected, it will show "On".

Figure 4: Digital inputs layout

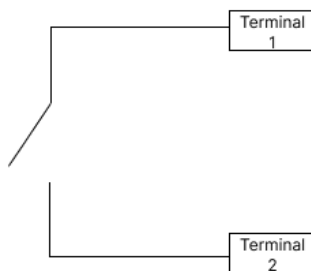

### 2.3.1.3 Digital Outputs

Digital outputs are found in the 3<sup>rd</sup> bank of terminals in the EMS Panel. They function as dry contacts. The "Digital Outputs" on the odd terminals (7,9,11 etc.) are the positive terminals. The even terminals (8,10,12 etc.) are ground terminals to complete the circuit.

Figure 5: Digital Output layout

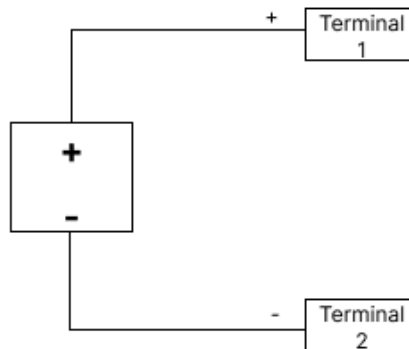

## 2.4 Installation Steps

This section will guide you through a step-by-step process for fitting and installing the EMS Panel. It will be broken down into sub tasks.

### 2.4.1 Site Inspection

A site inspection will need to be conducted to determine the appropriate location to install the EMS Panel. inspect the site to see where it would be appropriate to install the EMS Panel. It is advisable to minimise the RS-485 Cable runs.

If there is no option but to run cables near high power lines, the following steps must be adhered to:

- Use shielded cables.
- Run the cables at a minimum of 100mm away from the high-power lines when running in parallel.
- It is acceptable to run the communications cables perpendicular to the high-power lines.

### 2.4.2 Mounting the EMS Panel

After the panel's position has been determined, proceed to mount the EMS Panel.

The panel has four wall mounting brackets to attach to a wall. These brackets will need to be screwed onto the back of the panel before mounting it to the wall. It would be preferable to use bolts or screws of at least 5mm diameter. As the panel has a sizable mass.

Figure 6: Panel mounting holes

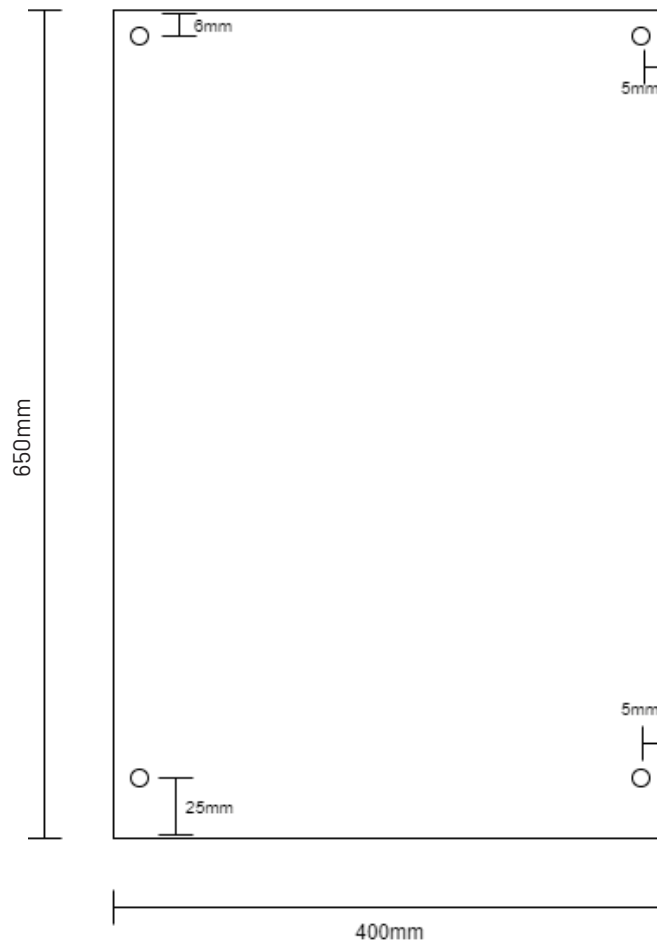

### 2.4.3 Connecting Power to the EMS Panel

The EMS Panel takes **230V AC** to power the system.

Before connecting the EMS Panel to power, ensure that all breakers in the panel are in the down position and that power is disconnected from the working area.

The EMS panel is powered by a permanent source such as a Distribution Board (DB). This DB board should be on AC output load of the inverter being monitored. This assists in keeping the EMS panel powered as consistently as possible.

Install the 6A circuit breaker in the DB board and run the 1mm<sup>2</sup> cable from this breaker to the EMS panel terminal inputs.

- There are 3 power input terminals in the bottom left of the EMS Panel, named PE, N and L. The layout for these is as follows:

TABLE 5: POWER TERMINALS

Terminal Name	Function
E	Earth
N	Neutral
L	Live

## 2.4.4 Connecting Communication Cables

Special care needs to be taken when connecting the communications cables to ensure the correct pins are used and that the cable runs are in the appropriate place.

When planning the cable runs, ensure that they are not near any high-power lines. If there is no other option, then adhere to the following guidelines:

- Use shielded cable.
- Run the cables at minimum 100mm away from the high-power lines when running in parallel.
- It is acceptable to run the communications cables perpendicular to the high-power lines.

Figure 7: Cable run examples

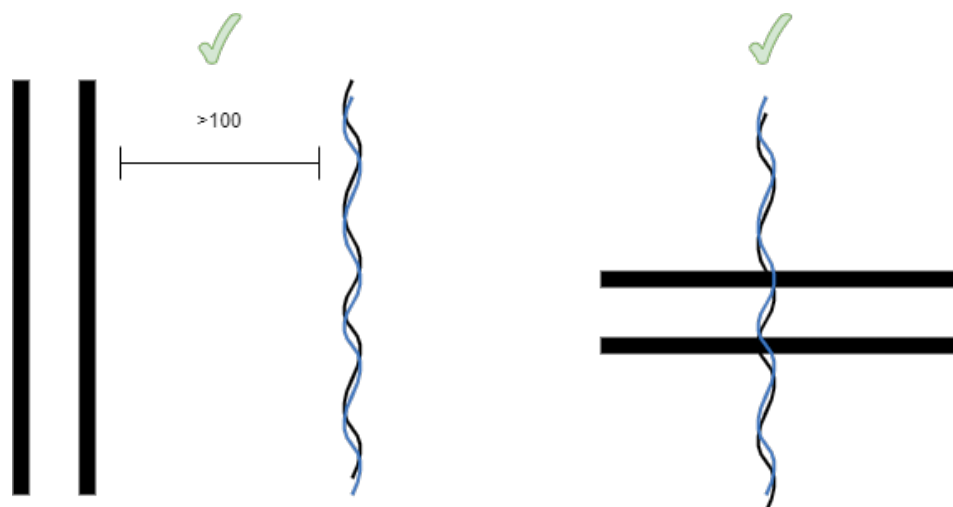

### 2.4.4.1 RS-485 connections

For the RS-485 Connections it is advised to use a Belden Shielded twisted pair or a similar cable. A suitable alternative is a CAT6 Ethernet cable.

For the pairing of the Modbus A+ and B- it is then imperative that you use a specific twisted pair in the CAT6 ethernet cable, for example, Orange and Orange/white and to not cross or mix colours.

When connecting to the various Modbus RS-485 enabled controllers it is important to note the sign and type of pins on the device. Ensure that one wires the EMS **A+** and **B-** of each Comm Port to the appropriate A+ and B- of the controller being connected.

**Note:** Some controllers denote their Comm Ports as **A-** and **B+** in this case follow the sign denotation of the **+** and **-** rather than the **A** and **B** notation.

## 2.4.5 Configuring 3<sup>rd</sup> party controllers

Each controller connected to the EMS panel needs to have its communication protocols set correctly for the EMS system to communicate with them successfully. It is imperative that the communication settings on the controllers, sensors and any systems connected to the EMS Panel are setup exactly as described below to have a successful connection.

The EMS Panel uses preconfigured RS-485 settings to streamline the installation and commissioning process.

[Atess EMS Installation Wiki](#)

[SUNGROW EMS Instal Wiki](#)

**Note:** Ensure there is stable internet connectivity on site as some devices/inverters etc require a mobile App to change these settings and those App's will require internet to function.

### 2.4.5.1 RS-485 Based controllers

For the RS-485 controllers, the communication settings, you will need to go into the menu/settings on the physical controller, either on its keypad or its appropriate software or connection.

The following settings need to be set for the communications to work with the EMS system.

TABLE 6: MODBUS RS-485 NETWORK CONFIGURATIONS

Description	Set
Modbus Slave ID	Unique per controller on the Modbus Network. Take note of what ID the controller was set to as this will be required when setting up the Cloud Portal
Baud Rate:	9600pbs
Data bits:	8
Parity:	None
Stop Bits:	1
Modbus Type	Modbus RTU

### 2.4.5.2 Modbus TCP Based Controllers

For the Modbus TCP controllers, the communication settings will need to be changed individually on the controller/device. You will need to go into the menu/settings on the physical controller/device, either on its keypad or its appropriate software and change the communication settings appropriately.

Special care needs to be taken when configuring the Modbus TCP network. The IP addresses must be unique per device. The IP addresses must be setup identically on the Cloud Portal during configuration as they are set on site.

TABLE 7: MODBUS TCP NETWORK CONFIGURATIONS

<b>Modbus Slave ID</b>	Unique per controller on the Modbus Network. Take note of what ID the controller was set to as this will be required when setting up the Cloud Portal
<b>IP Address</b>	192.168.35.XXX -(Unique to the device being connected)
<b>Subnet Mark</b>	255.255.255.0
<b>Default Gateway</b>	192.168.35.1

### 2.4.6 Connecting the Internet to the EMS Panel

Internet needs to be provided to the EMS panel from a source on the site. This is so the system can send its data to the cloud and be accessed remotely.

To do this, run an Ethernet cable to the LAN 1 port on the Glacier Edge PC in the EMS panel.



The EMS Panel internet (WAN) input is set to DHCP, so if there is an internet connection available, it will assign itself an appropriate IP address and connect.

**Note:** The system will still run locally if the internet connection fails for any reason. The data will be stored on the Glacier Edge directly, and once a connection is reestablished, it will upload its data and synchronise with the Cloud again. All logic and running of the site software will continue to run uninterrupted.

## 2.4.7 Connecting the GSM Antenna

The EMS Panel comes with a built in SIM card and GSM connectivity for Freedom Won Remote support. This connection will not upload or grant access to clients. It is used solely to provide emergency access to the site and the EMS Panel remotely. This service can only be accessed by contacting the Freedom Won support team directly.

For this emergency service to function the GSM Antenna will need to be installed correctly to enable the Glacier Gateway to connect to the available cellular networks.



As shown in the figure, the antenna provided will need to be connected to the Glacier PC's antenna connector.

The antenna must be positioned in an open area and as high up as possible to get the best signal. The base of the antenna is magnetic and can be placed on top of the panel itself.

The best practice is to ensure the antenna is placed outside when possible.

Do not run the antenna cable or place it near any high-power cables or transformers as this will disrupt the signal strength.

## 2.4.8 Connecting the backup batteries

Once all the connections have been run and the site is ready to power up, it's time to connect the backup battery.

In the EMS Panel there will be a set of battery terminal connectors coming out the trunking on the right-hand side. They will be colour coded. Red Cable – Positive, Black Cable – Negative.

Place the battery in the panel and connect the red cable to the positive terminal and the black cable to the negative terminal.

The EMS panel has a combined 7.5Ah of backup battery capacity which will run the EMS Panel and system without external power for a limited amount of time.

## 3. Getting Started

### 3.1 Power ON

Now that the system has been successfully installed based on the procedure above and the site is ready to receive power we can power on the system.

To do this, you need to follow this procedure:

1. Switch on the 6A breaker in the DB board,
2. Switch on the 6A breaker in the EMS Panel
  - 2.1 If there is power on the site, the system's lights should come on.
  - 2.2 If there is no power on the site proceed to the next step to run the EMS Panel on its backup batteries.
3. Switch on the 6A breaker for the battery
  - 3.1 If there is no mains power the system will now power on and run off its backup battery.
  - 3.2 If there is power from mains in 2.1 then the system will begin to charge the batteries.

### 3.2 Lights on the EMS Panel

There are two lights on the front face of the EMS Panel, they are denoted "Power" and "Error"

The power light indicates that there is AC or battery power coming into the EMS Panel.

The Error light indicates that there is an Error on the EMS system.

### 3.3 Commissioning of Devices

Commissioning the site means adding the various devices installed on site to the Cloud Portal. In this step we will take the Modbus RS-485 settings and the TCP settings and set the controllers/devices on the Cloud with the same settings.

These devices will be commissioned online through the Polar Cloud. Follow the link below to set up an account and add devices.

For assistance on these units please contact Freedom Won support for the 1<sup>st</sup> time setup procedure.

[Click here](#) for basic instructions on how to use the Cloud Platform.

**Note:** An internet connection is required to finalise and test the setup of the EMS Panel

Each Polar Monitoring Glacier Edge EMS Panel has a unique serial number. Use this serial number to begin the setup procedure under the Gateways tab on the Cloud.

## 4. Troubleshooting

### 4.1 Power switch not working.

If the power light does not illuminate, it means that the EMS Panel is not getting power. This light will only illuminate if there is 230V AC power to the system.

Ensure that the DB supplying the EMS panel is on the output of the inverter and that the inverter is powered on and giving out 230V AC supply from each phase to neutral.

### 4.2 Error light staying illuminated.

The Error light illuminating on the front of the panel is an indication of one of two things:

**Option 1:** The first is that there is no internet connection to the EMS panel.

In this case check the internet connection on the site to ensure it is up. Alternatively, check the Ethernet cable providing the internet connection to the EMS Panel to ensure there is no damage to the cable and that it is secure into the Glacier LAN 1 port.

If there is internet connection to the panel and the ethernet cable is in working order, then there could be firewall issue on the network preventing the EMS Panel for gaining an internet connection. Contact your IT administrator to open the firewall for the EMS Panel.

**Option 2:** The second is if there are any communication failures between the EMS Panel and the controllers/ devices connected to it. This means that there is a device/ controller setup on the Cloud that is not sending its info back to the EMS Panel.

Firstly identify which controller/ device is having the issue by looking at the data on the Cloud and seeing which one is not sending its data through. Once identified,

1. Check all the communications cables going to this device/ controller
2. Double check the Comms settings to ensure that they are set correctly.
3. Ensure that the same Modbus Slave ID that is set on the Controller/ device is the same as the one set on the cloud.

### 4.3 Not getting communication to a controller on the site

Communication failures between the EMS Panel and the controllers, devices connected can have a number of causes. This will manifest itself as a controller/device setup on the Cloud is not sending any data upstream.

Firstly, identify which controller/ device is having the issue by looking at the data on the Cloud and seeing which one is not sending its data through. Once isolated,

1. Check all the communication cables going into the device/ controller. Search for any signs of damage, where they are plugged into the terminals, etc. Double check the Com Settings to ensure that they are set correctly.
2. Ensure that the same Modbus Slave ID that is set on the Controller/ device is the same as the one set on the cloud.

## 5. Upgrades

Upgrades to the system happen on a constant basis via the Cloud. There will be new software versions for updating on the physical Glacier Edge gateways in the EMS panels that can be downloaded.

The Cloud Portal will ever be evolving and automatically updating to bring you the best service possible, keep an eye on our Change Log here to view the latest changes and updates to the system as they get published.

Upgrades to the system, we can talk about additional upgrade panels.

## 6. Maintenance

The maintenance on the EMS panel is basic. Keep the panel clean and free from water ingress and the system will function for many years to come.

The Freedom Won batteries if cycled regularly will need to be changed every 5 years to ensure perfect redundancy on the power backup for the EMS Panel.

Do visual inspections of the EMS Panel and Cables at least once a year to ensure that there is no damage and that all connections are still secure.

## 6.1 Help and Support

For help and support please contact Freedom Won’s technical team.

1. Go to [www.freedomwon.co.za](http://www.freedomwon.co.za)
2. Click the “Contact” tab
3. At the bottom right of the page, follow Support Enquiries and Request Technical Support
4. Click on “New support ticket” to open a new support ticket, as shown in the image below

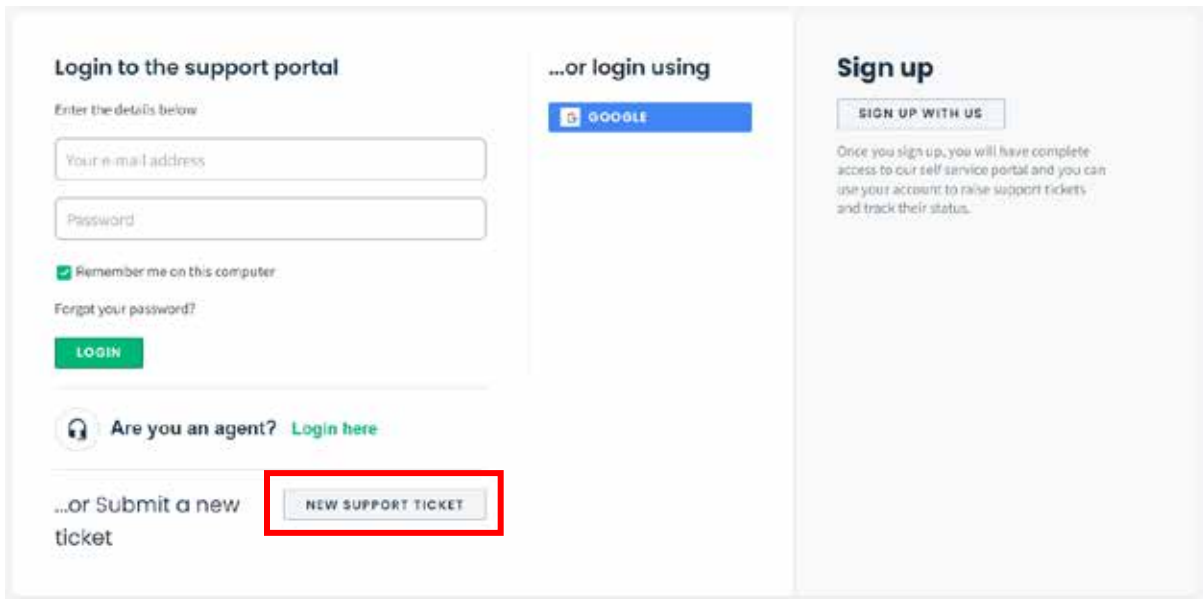

Details:

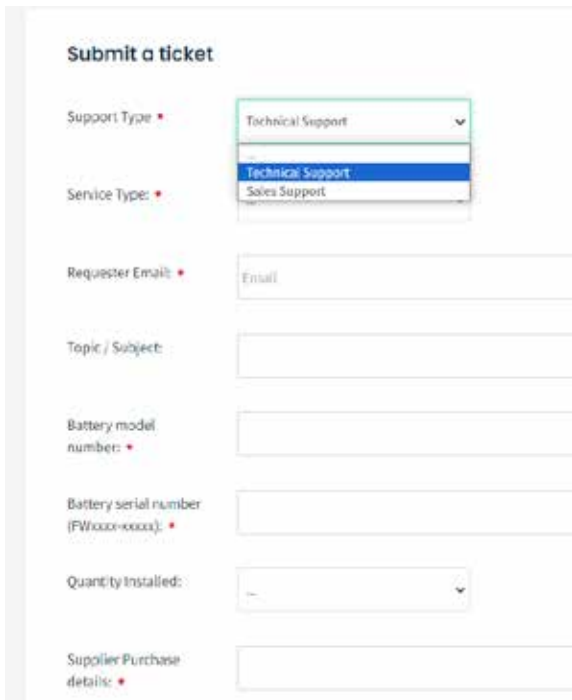

Choose Technical Support from the drop-down menu that appears.

**Submit a ticket**

Support Type:

Service Type:

Requester Email:

Topic / Subject:

Battery model number:

Battery serial number (FWxxx-xxxx):

Quantity installed:

Supplier Purchase details:

Installer details:

Installer details:

Site location details:

Inverter used:

Electrical Installation type:

Remote connection available to inverter and or battery pack:

Provide User Access to related Inverter Portal (Link and username if available):

Access to battery programming cables:

Description of the problem experienced (Attach Images of Installation):

Complete all the required fields on the support form and click "Submit" to submit the form.

Alternatively, contact the Freedom Won Technical support team on [enquiries@freedomwon.co.za](mailto:enquiries@freedomwon.co.za) and +27 10 597 7794.