

FW12-30-S Starter Battery – Lithium Iron Phosphate (LiFePO4)

SUMMARY DATASHEET – January 2019

*This Starter Battery is designed for delivering very high peak current as required for starting internal combustion engines used in lawnmowers through to large diesel generators and trucks. **Cranking Power** – Offers 200% more power than lead acid Longevity and performance is guaranteed by using high quality LiFePO4 cells.*



Typical Applications (note: 8Ah model also available):

- Motorcycles
- Ride on Lawnmowers
- Petrol driven Golf Carts
- Petrol and Diesel Generators
- Cars and Trucks
- Portable emergency starter packs

Features of the Freedom Won LiFePO4 starter batteries:

Cranking Power – Offer 200% more power than lead acid starter batteries even in very cold conditions – results in fast unlaboured starting

Service Life – LiFePO4 offers unprecedented service life to the starter battery >15 years in harsh starting duties

Temperature Resilience – Service life is largely unaffected by the high under bonnet temperatures that quickly damage lead acid batteries.

Safety – Freedom Won starter batteries are thermally stable, contain no harmful chemicals, and release no gases; making them far safer than lead acid batteries – risk of explosion is eliminated

Self-Discharge – These batteries can be left disconnected and unused for 12 months or more without substantial self-discharge, unlike lead acid batteries that require constant attention owing to high self-discharge rates.

Flexibility – 24V vehicle systems can be accommodated using two batteries in series

Dimensions

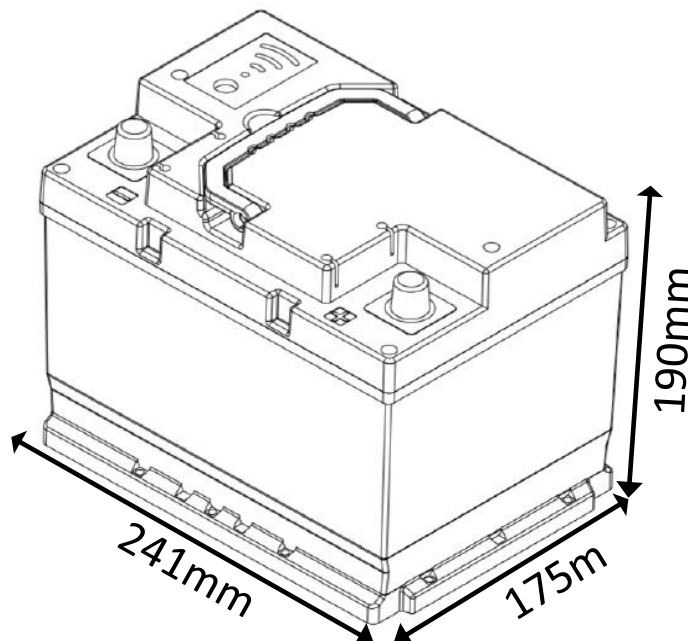

Specifications

Model Name	FW-12-30-S
Current Capacity [Ah]	30
Max Energy at 100% DoD [kWh]	360Wh
Nominal Voltage	12,8V
Discharge Cut Off Voltage	8V
Standard Charge Current	30A
Maximum Continuous Charge Current	90A
Charge Voltage Range	13,8V to 14,6V
Maximum Continuous Discharge Current	180A
Maximum Discharge Current (peak for 3 seconds)	900A
Weight	5kg
Operating Temperature Range	Charge – 0 to 60°C Discharge – -30 to 80°C
Storage Temperature Range	0-40°C
Self-Discharge	<3% per month
Protection Rating	IP67
Cell Chemistry	LiFePO4
Terminal	Standard Automotive
Warranty	5 years unlimited use
Design Life	>15 years

www.freedomwon.co.za